



This is a digital copy of a book that was preserved for generations on library shelves before it was carefully scanned by Google as part of a project to make the world's books discoverable online.

It has survived long enough for the copyright to expire and the book to enter the public domain. A public domain book is one that was never subject to copyright or whose legal copyright term has expired. Whether a book is in the public domain may vary country to country. Public domain books are our gateways to the past, representing a wealth of history, culture and knowledge that's often difficult to discover.

Marks, notations and other marginalia present in the original volume will appear in this file - a reminder of this book's long journey from the publisher to a library and finally to you.

Usage guidelines

Google is proud to partner with libraries to digitize public domain materials and make them widely accessible. Public domain books belong to the public and we are merely their custodians. Nevertheless, this work is expensive, so in order to keep providing this resource, we have taken steps to prevent abuse by commercial parties, including placing technical restrictions on automated querying.

We also ask that you:

- + *Make non-commercial use of the files* We designed Google Book Search for use by individuals, and we request that you use these files for personal, non-commercial purposes.
- + *Refrain from automated querying* Do not send automated queries of any sort to Google's system: If you are conducting research on machine translation, optical character recognition or other areas where access to a large amount of text is helpful, please contact us. We encourage the use of public domain materials for these purposes and may be able to help.
- + *Maintain attribution* The Google "watermark" you see on each file is essential for informing people about this project and helping them find additional materials through Google Book Search. Please do not remove it.
- + *Keep it legal* Whatever your use, remember that you are responsible for ensuring that what you are doing is legal. Do not assume that just because we believe a book is in the public domain for users in the United States, that the work is also in the public domain for users in other countries. Whether a book is still in copyright varies from country to country, and we can't offer guidance on whether any specific use of any specific book is allowed. Please do not assume that a book's appearance in Google Book Search means it can be used in any manner anywhere in the world. Copyright infringement liability can be quite severe.

About Google Book Search

Google's mission is to organize the world's information and to make it universally accessible and useful. Google Book Search helps readers discover the world's books while helping authors and publishers reach new audiences. You can search through the full text of this book on the web at <http://books.google.com/>



MANUAL TRAINING-PLAY PROBLEMS FOR BOYS AND GIRLS



W. S. MARTEM



LELAND STANFORD JUNIOR UNIVERSITY

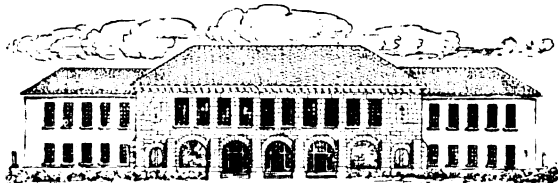

SCHOOL OF EDUCATION
LIBRARY





LELAND STANFORD JUNIOR UNIVERSITY

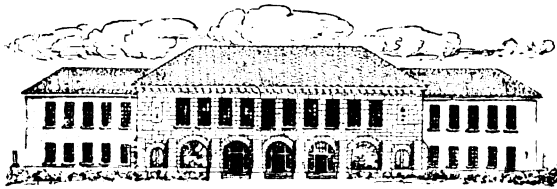

SCHOOL OF EDUCATION
LIBRARY



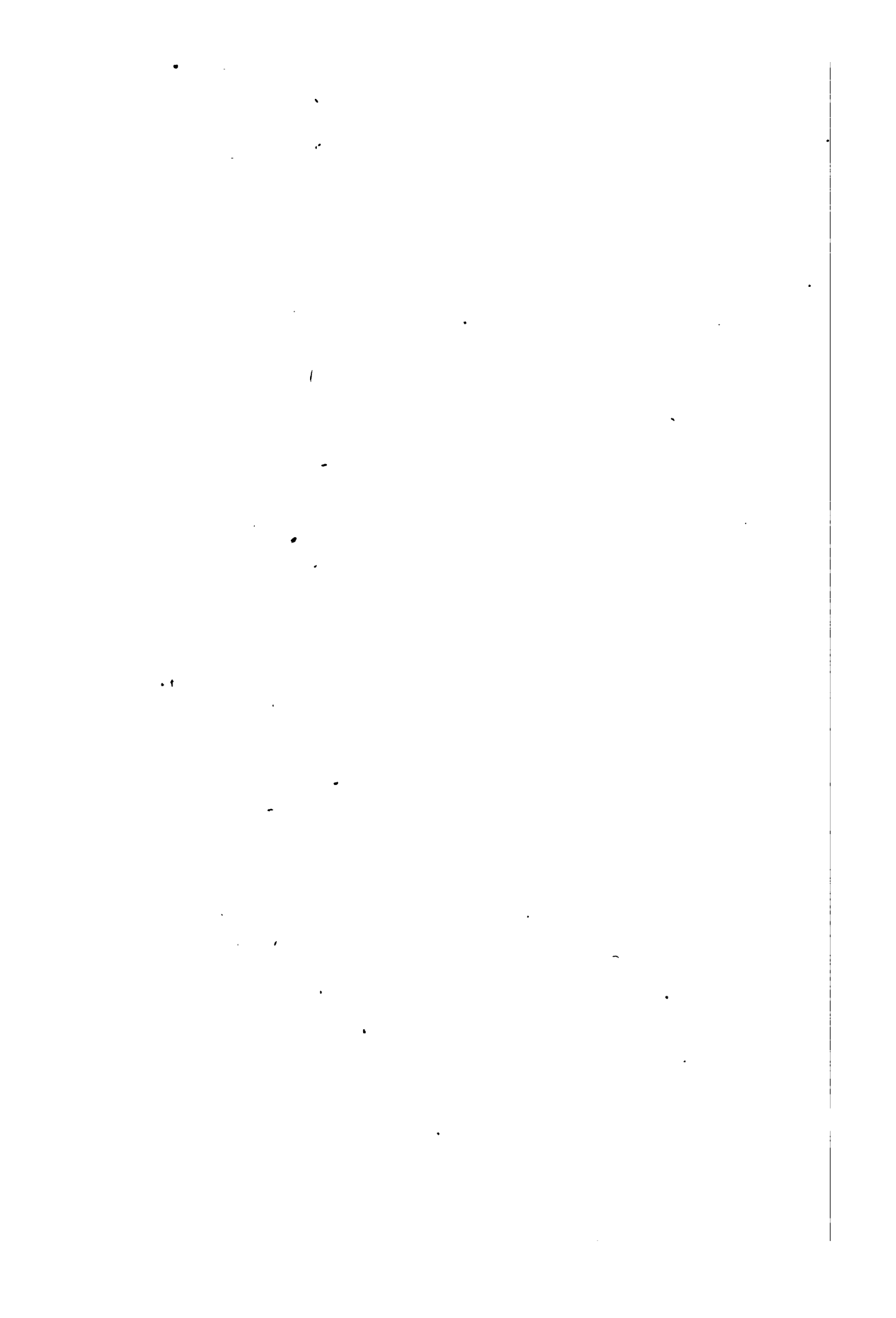

MANUAL TRAINING — PLAY PROBLEMS

**CONSTRUCTIVE WORK FOR BOYS AND GIRLS BASED
ON THE PLAY INTEREST**



THE MACMILLAN COMPANY
NEW YORK · BOSTON · CHICAGO · DALLAS
ATLANTA · SAN FRANCISCO

MACMILLAN & CO., LIMITED
LONDON · BOMBAY · CALCUTTA
MELBOURNE

THE MACMILLAN CO. OF CANADA, LTD.
TORONTO

MANUAL TRAINING—PLAY PROBLEMS

CONSTRUCTIVE WORK FOR BOYS AND GIRLS BASED
ON THE PLAY INTEREST

BY

WILLIAM S. MARTEN

DEPARTMENT OF THE INDUSTRIAL ARTS, STATE NORMAL SCHOOL
SAN JOSE, CALIFORNIA

AUTHOR OF "INEXPENSIVE BASKETRY"

*WITH WORKING DRAWINGS AND ILLUSTRATIONS OF SEVERAL HUNDRED
VARIOUS PROBLEMS*

STANFORD LIBRARY

New York

THE MACMILLAN COMPANY

1917

All rights reserved

1 (3)
141-11



The Evolution of the Clermont. Progress of Boat Building which led to the Clermont
(Courtesy of Miss Grace C. Parsons, Vocational School, Albany, N. Y.)

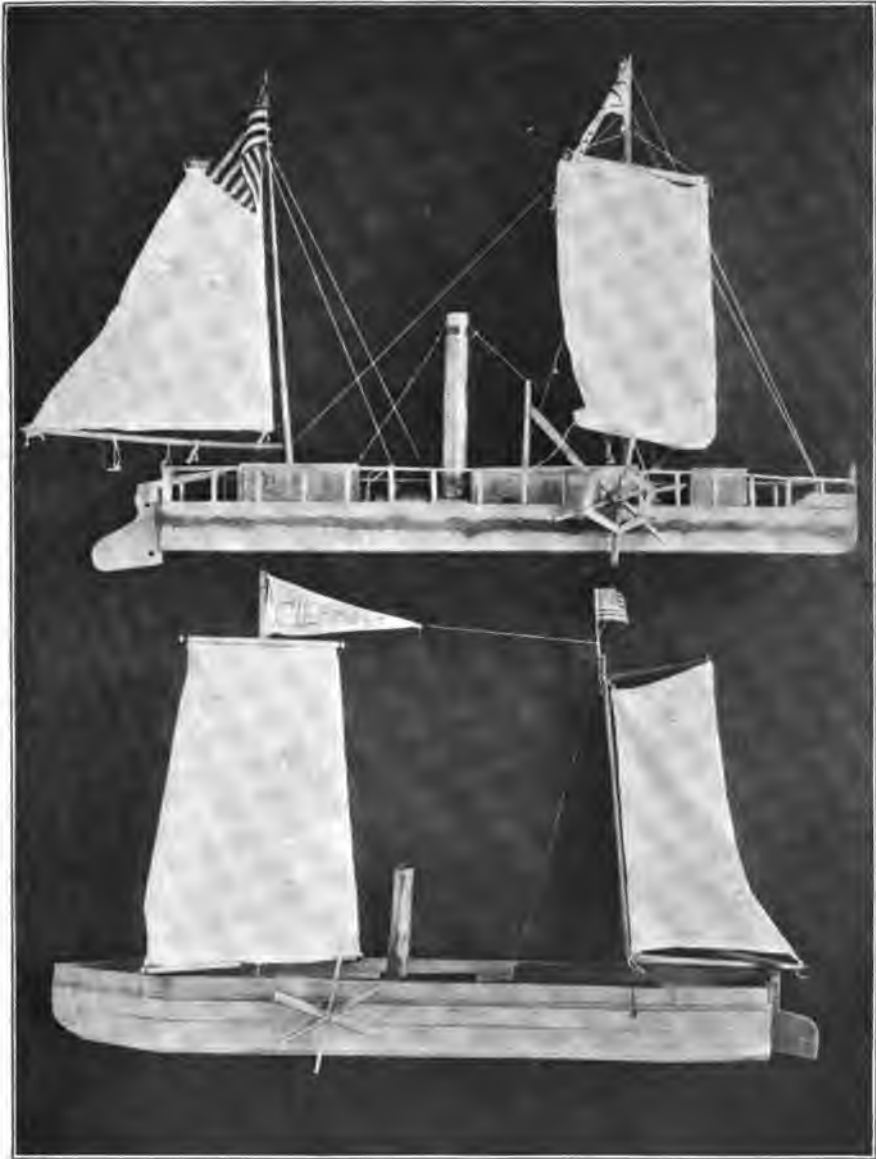

The Clermont

(Courtesy of Miss Grace G. Parsons, Vocational School, Albany, N. Y.)

**"The value of constructive play as a factor in development
is an unworked educational mine."**

—EDGAR JAMES SWIFT.

FOREWORD

WHEN teaching manual training in the upper grammar grades, I announced that a special class would be formed the next afternoon for all boys interested in special work. Two dozen applicants met the next afternoon after school. It was agreed that we should call ourselves the "Experimental Mechanics," that the hours should be 3:30 to 5:00 each afternoon after school and 10:00 to 12:00 each morning on Saturdays and holidays, and that punctuality would be required for each boy to hold membership in the class.

Personal Experience with the Constructive-Play Interest of Children the Incentive for Organizing the Problems.

The morning of Thanksgiving Day, Clinton Toms, a son of the



Work of High Sixth Grade. Crocker Intermediate School, San Francisco, Cal.

(Kindness of Mr. H. M. Bernhard)

superintendent of several of the large factories of the city, came in fifteen minutes late.

"Why, Clinton! What does this mean!" I said. "Oversleep yourself this morning?"

"No, sir. I was up before five o'clock. Papa said I must level up the front yard this morning, so I got up two hours before breakfast and worked until daylight with a lantern fastened to the wheelbarrow so that I could come over and work on my glider," was his reply.

On another morning two boys, whose parents did not permit them to join the "Experimental Mechanics," came to school quite late. Upon inquiry, I found that the boys had gotten up before daylight in order to try out in the near-by hills a large glider which they had constructed in a neighbor's barn. The glider came to grief, and the parents reprimanded the boys when they heard about it; but this did not deter the boys from later building a large-size aeroplane. Everything was ready for flying the aeroplane, except putting in the motor, when the parents became aware of the fact that the boys actually intended to fly it; and it too was destroyed, but in a somewhat different manner from the glider.

These instances of the interest in "constructive-play" activities manifested by the children, which continue so forcibly to come to my attention, have been the spur which has prompted me to organize such problems in available form so that the boys and girls can construct them at school or at home.

All the detailed problems herewith presented cover several years of personal work with children in the settlements and the vacation schools of New York City and Pittsburgh, and in the regular public schools in various parts of the United States. These problems are practical for school work because we have tried them out on the playground and in the school workshop. In thus being tested, faults of construction have been found and corrected, and improvements in design have been made. I have found that working from the drawings of a problem that has not been tested by experience is oftentimes a costly experiment. Many of the problems suggested in the

boys' magazines have simply been worked out of an adult mind; and, when these directions for construction are followed by the boy, the object has oftentimes failed to work. Unless the boy is especially talented or has some one to help him over the obstacles, the difficulty has been so dismaying that it has put a damper on his future self-effort. By having the drawings and photograph accompany definite suggestions for the construction of each problem, I have found that it is possible to have the children at school or at home intelligently construct objects that are a source of satisfaction and pleasure to themselves.

I wish to express my sincere thanks to the many friends who have so kindly helped me with their suggestions and criticisms, and especially do I thank the boys and the girls who have so generously and willingly made the various problems that are shown in the photographic illustrations.

WILLIAM S. MARTEN.

State Normal School, San Jose, Cal.
October 21, 1916.

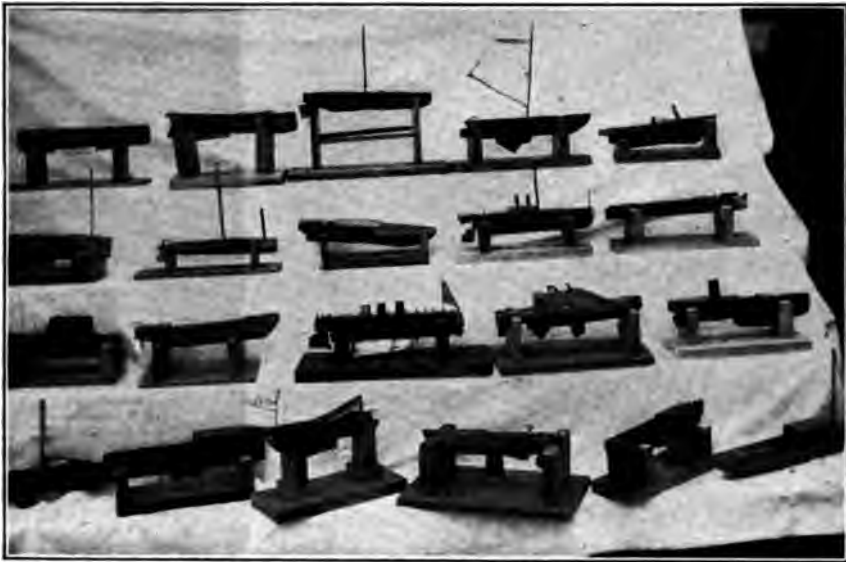

Boats made by a Sixth Grade Class. Horace Mann School, San Jose, Cal.
(Courtesy of Mr. Louis C. Butler)



Roller Coasting



Bowgun Shooting



Seventh-grade Class on Stilts, Durham, North Carolina

CONTENTS

	Page
The Teachers' Point of View	xv
Suggestions about Construction and Use of Tools	xix
Tops; spool, color, butterfly, plug, disc, etc.	2
Cigar box furniture and other problems; table, davenport, cradle, wash-stand, etc.	4
Butterfly and whirligig or flying top	6
Ring toss games; with string and stick, and ring and hook	8
Buzzer and primitive string drill	10
Garden sticks, sign, trellises, and labels	12
Kaleidoscopes	14
Bean bag games	16
Rustic furniture; porch chair, divan, tables, and benches	18
Eccentric running wheels	20
Pistol and sling shot	22
Running wheels	24
Traps; figure 4, barrel and box	26
Boats; toy rowboats and power paddle-wheel boats	28
Insect bottles and nets; butterfly, minnow, and polliwog	30
Windmills and vanes; single, double, Happy Jack, Mother Hubbard, etc.	34
String and whistling instruments; zither, banjo, fife, whistle, and humming bird	38
Swings; porch and playground	42
Map and post card picture puzzles	44
Print frames	46
Jacks; scissors and dancing and clothespin	48
Jacks; climbing and jumping	50
Jacks; gymnastic and pole	52
Lever movements; clothespin blacksmith boys, chicks with worm, wrestlers, etc.	54
Knives and daggers	56
Tip cats or peggies	58
Peggy bats	60
Fencing rods or swords	62

	Page
Roque and croquet game boards	64
Solitaire boards	66
Marble games, rakes or bridge board	68
Stilts	70
Shinney and hockey sticks, pucks and shin guards	72
Bow guns	74
Swiss dinkey birds with pendulum; head and tail movements	78
Swaying figures; animals and honest woodsman, or sawyer with pendulum	80
Falling teeter or seesaw, and ladder	82
Looms for weaving	84
Root cages or vivaria	86
Bird houses	88
Box traps	90
Ring toss games and quoits	92
Rattlers and clickers	96
Aëroplanes and gliders	100
Animals with movable parts	102
Spreader, press, and mounting case for nature-study work	104
Roller coaster	106
Tables	108
Morris chairs and cushions	110
Beds	112
Garden tools; rake, spade, hoe, and shovel	114
Seesaw and sand box	116
Dolls — jointed	118
Running grasshoppers with moving parts	120
Sailboats	122
Wheelbarrow and wagon	124
Roller coasters, autos, and wagons	126
Vaulting pole, vaulting or jumping standard, and hurdle	128
Checkers, chess, and bagatelle boards	130
Roller looms for continuous weaving	132
Aquarium, vivarium, or breeding cage	134
Dolls — jointed	138
Davenport and chair	140
House plan arrangement	142

THE TEACHERS' POINT OF VIEW

It is true that the present existing conditions of school work are far from what they should be. Smaller classes, more time and material for constructive work, and better equipment are important conditions necessary to secure good results in school work, but more important than these are the intelligent selection of equipment and obtaining of supplies as well as proper class management. The wise class teacher knows that too much individual instruction is as bad, if not worse, than the formality necessitated by large classes, that the boys and girls should to some extent be thrown upon their own resources and left to think out for themselves the solution of their own problems. The wise teacher also considers equipment in its application to conditions. The writer has seen most successful vacation school work in poor districts carried on with a very meager equipment, when only such tools and materials as entered into the home life of the children were available. In other poor localities of the same city where the best of equipment was secured, the result was a failure because the tools and materials furnished did not carry over into the home life of the children. The result of this well-intentioned but unwise effort made the boys dissatisfied with home conditions because the tools and materials provided were outside of the reach of the boy in his own home life. The best benches and tools were installed, and wood was secured from the mill in perfect condition for assembling, rather than using improvised benches and making use of packing boxes, cigar boxes, old clock works, cereal boxes, barrel hoops, and scraps thrown out by industrial plants.

The Proper
Viewpoint
Concerning
Supplies and
Equipment.

In many places the writer has made arrangements with the factories to obtain at slight cost materials that were used for the shop work problems. For instance, for the summer school work of the **Economy of Materials.** Playground Association of Pittsburgh, Pa., we obtained from one of the box factories enough strips of wood, simply at the expense of the hauling, to supply all of the vacation schools with material to make many problems requiring thin strips, such as toys, gliders, and kites. From another woodworking mill we obtained loads of the select pieces of scrap wood and supplied this to each of the schools. This wood sold for firewood was used to make the smaller problems. Children were encouraged to bring in and make a collection of odds and ends that served a purpose in this kind of work. A list of usable things was brought to the attention of the children so that they knew what to collect. The following is a list of things from which an intelligent selection will be found useful for this work:

aluminum	carbons	feathers	plaster-of-Paris
axles	cardboard	flowers	potatoes
bark	cardboard boxes	fruit baskets	prunes
barrel staves	cattails	glass	raffia
berry boxes	cement	grasses	rag
bicycle parts	clay	hogsheads	raisins
bicycle spoke	clock works	leather	reeds
bolts	cloth	leaves	rivets
boxes	clothespins	newspapers	sand
box edgings	copper	nuts	screws
brass	cord	old envelopes	seeds
broomsticks	corncobs	packing boxes	sheet iron
buttons	corset steels	paper	shells
button molds	cotton	passe-partout	shoe boxes
candles	cotton spools	peanuts	skewers
candy boxes	drug boxes	peas	soap
canes	egg shells	pebbles	splints
canvas	envelopes	pins	spools

steel	thin wood	twigs	wheels
straws	tin	vegetables	wire
string	tin cans	venetian iron	yarns
strip iron	tin foil	walnuts	zinc
tarboard	tooth picks	wood	

Excellent training and economic advantages are gained in making use of the odds and ends and raw materials at hand. Storage closets, corner shelves, or boxes should be provided in which to keep the assortment of various things thus collected. By no means allow this storage closet to become simply a pile of junk. Remember that system and order is necessary in caring for all supplies. Even greater care is necessary in handling this kind of material.

The following suggestions will give some idea of possible economy in the use of materials: (1) box edging, from box factory, for kites, gliders, and thin wood toys requiring strips; (2) select scraps of wood from the woodworking mills for various small problems; (3) hogsheads and barrel hoops and staves, and reeds and cattails, for bows and arrows; (4) tin waste from factories, and tin cans for parts of toys, etc.; (5) orange crates for kites and all thin wood problems; (6) packing boxes for house furnishing rooms; (7) springs, wheels, and old clock works for toys and elementary science apparatus; (8) cereal boxes, candy boxes, etc., for house furnishing problems; (9) cigar boxes for thin wood projects requiring boxes; (10) drug packing boxes for ring toss, games, etc.

To construct the object it is necessary to understand the drawing. In order that the boy or the girl may understand the drawing more easily, the photograph and the accompanying suggestions are offered as a help. To clearly understand the drawing and printed directions, it is important that the materials and tools be taken in hand. As the work progresses under these conditions the directions will become clear to the worker. Some advantages of these drawings lie in the freedom that is possible in planning the problems (the dimensions given are intended as suggestions only); the possibility of individual expression in form,

Use of the
Drawings,
Photographs,
and Printed
Directions.

outline, and decoration; and the possibilities for individual creativeness and inventiveness in the mechanical arrangement of parts and movements.

There are many opportunities for the play of individuality even in the large classes if a reasonable amount of time is taken for the preparation of the lesson and for its execution. Almost any problem can be used as a type, and with it various modifications of proportion and outline are possible. With paper and scissors in the hands of the pupils, individual outlines can be developed, and these can be used as templates or patterns. In thus working out the outlines it is important that plenty of time be allowed for class discussions of good and bad proportions of the patterns cut. A careful leading up to the final results is bound to produce satisfactory results. In cases where time for this development is not possible, patterns worked out by capable pupils or by the teacher must be provided.

SUGGESTIONS ABOUT CONSTRUCTION AND TOOLS

On account of the hard usage the objects made are bound to receive, it is important that they be strongly constructed.

For this reason it is often best to use bolts for fastening parts together instead of nails as is usually done. It is well to have small dies on hand for cutting threads on wire that can be made into bolts. Two sizes of dies will be found to be very convenient; one, such as is used for cutting threads on bicycle spokes, and another one, $\frac{1}{8}$ " will be very convenient. Nuts to fit these sizes can be purchased at the bicycle shop or hardware store. Dies are not expensive, and an assortment of small sizes is most desirable to have on hand. If these are not available, an assortment of small-sized bolts should be kept on hand. For cutting the wire and bolts a hack saw is convenient, but it is not a necessity as the wire or rod can easily be broken off by notching on each side with a file and then bending back and forth a few times.

Use of Bolts.

When nails are used to fasten pieces together, two nails should be put in at each joint so as to secure or brace the joint thoroughly. One nail at a joint only serves as a pivot. To secure a very strong piece of work, the nails should be clinched. Common wire nails, because they have large heads, are better to use than brads. To clinch nails, use ones long enough for the points to go through and project slightly. The nails can be clinched if the wood is placed on a flat metal surface and the nails hammered down firmly. The points will be forced over by the metal surface. If the metal surface is not available, place the work on a block of soft wood or locate the nail directly over a hole and drive the nail in place; then turn the work over and with the nail head resting on a solid surface, turn over the point and hammer it down firmly. When nails are used and cannot be clinched, they hold more effectively if driven in at various angles. To prevent slender brads from bending, pinch them

Use of Nails.

tightly while driving them in. Never attempt to use brads that have once been bent. Never drive nails in small pieces or in thin pieces without first starting the nails by means of a hole bored slightly smaller than the nail. If the piece is to pivot freely, the hole should be slightly larger than the nail. These holes are usually made with brad-awls or drills.

In fastening with screws, to obtain efficient results, a hole should always be bored through the upper piece to receive the screw. This hole should always be large enough for the screw to slip in without forcing. Any binding on the shank of the screw lessens the force of its pull. The size of these holes for No. 6, No. 10, and No. 14 screws should be $\frac{1}{8}$ " , $\frac{3}{16}$ " , and $\frac{1}{4}$ " , respectively. If soft wood is used, it is not necessary to bore a hole into the piece in which the point of the screw fastens ; but if hardwood is used, it is necessary to bore a hole slightly smaller than the thread of the screw. The screw should not have to be forced in hard, else the head of the screw is liable to be broken off. A little wax or soap will enable screws and brads to go in much easier. When dowels or round rods are needed, they can readily be made by planing a stick to nearly the required size in diameter and then driving it through a hole bored in a block of iron or hard wood.

Because the brad-awls and drills break so easily, they are very expensive. It is unnecessary to use either, since a very effective drill can be made from a nail or brad. Select one the desired size of the hole, cut off the head, and grind or file one end of it wedge-shaped, that is, flattened on two opposite sides. If better drills are desired, use a hat pin, needle, or other steel wire. Save these improvised drills and a various assortment will soon be on hand ready for use. They can best be used in the ordinary hand drill, but if this is not available they can be used in a brad-awl holder or fastened into a piece of hard wood and used as a brad-awl.

When button molds are too small to be used as wheels, a washer cutter should be used to make the wheels. This cutter can be set so that wheels any desired size of diameter can be cut out of wood $\frac{1}{2}$ " or less in thickness.

**Making of
Drills and
Wheels.**

For use with many materials, shellac serves as an excellent cement. It can be used successfully with nonporous substances, as metal and glass, where glue will not stick. Where a thin coat of shellac is evenly applied as a varnish, it dries very quickly.

**Cementing
Materials.**

To use shellac as a cement, apply two or three thin coats; then when partially dry, that is, when it is very sticky to the touch, place the surfaces together and keep them in position for several hours. For fastening thin materials to surfaces, such as lining the inside of a box with silk, first apply two or three thin coats of shellac to the inside of the box: then when the shellac is almost dry, that is, when it is sticky to the touch but will not adhere to the fingers, press the silk firmly in place. The ordinary fish glue which requires to be heated every time it is used is satisfactory for use with wood. Liquid glue such as Le Page's is satisfactory and is much more convenient. Powdered dextrine mixed with water to the consistency of library paste is most satisfactory for use with leather. Library paste is most satisfactory for use with paper and cloth. Flour paste can be quickly made by adding boiling water to flour until the proper consistency is obtained. If this paste is desired to be kept some time, it should be boiled for a little while, and powdered alum added. A few drops of essence of cloves will improve it.

When possible, have both hands free to hold and guide the tools. Never hold the work in the hand if it can be held some other way, because, with both hands free to work, better technique is possible and less time is required. The vise, bench stop, hand screw, and other such contrivances should be made use of. Common sense and a due amount of care must be exercised in the use of these things, else the work may be spoiled.

**Holding of
Work.**

In designing the construction of parts, monotony of proportions and spacing of parts should be avoided. A rectangular room is more pleasing than a square room, because of the variety in width and length. The rail or brace in a chair or table should never be placed so as to divide the spaces evenly; for instance, if it is necessary to fasten a rail or brace to the legs of a table or chair, it should never be put half way between the floor and

**Constructive
Design of
Furniture.**

the top of the table or the seat, but usually below the middle so that the space above will be wider than the space below the brace. Also, the width of the space should always be either less or more than the width of the brace. This same thought must apply to all lines and especially to the horizontal lines in the making of all pieces of furniture. When a finished surface is desired and nails must be used, the brads or thin finishing nails which have small heads should be used.

All of the pieces of furniture should be made strong enough to stand the hard usage they are bound to receive. In the design of furniture construction all ends which touch the floor should have the corners rounded or chamfered to prevent splitting the edges. All corners should have the sharpness worn off by the use of sandpaper. All parts should be well sandpapered and in some cases stained before assembling. If the wood is to be shellacked or stained, care must be taken that all roughness and marks are sandpapered out. The furniture of each room should harmonize in design and finish. It is well to stain all the pieces at one time, or at least use the same stain for all the pieces of a room.

Pieces should be sandpapered before assembling, and it is sometimes best to color them before assembling. Sandpapering should be done with a block and always with the grain, else it will show scratches.

Finishing. When finishing, stains and dyes are more satisfactory to apply and handle than paint, since the stains can be applied, rubbed over, and waxed without waiting for anything to dry, while the oil paint takes two or three days to dry thoroughly. Oil stains of any color can be readily made by thinning the oil paint with turpentine or by mixing the dry paint pigment in turpentine. Any shade of brown stain can be made by thinning black asphaltum varnish with turpentine. If a dull black is desired, use dead black "Japalac." The oil stain cannot be made intense in color as it does not penetrate the wood deeply. The dyes and water stains overcome this objection. They, however, raise the grain of wood and thus make the surface rough. This requires it to be sandpapered. A thin coat of white shellac over the stained surface will prevent the color of the stain from drying out. Water colors and inks are desirable

where small surfaces are to be covered, such as when used for facial expressions. Good bright colors should be used freely, as they add much interest to the use of the things made. If paints must be used, the enamel paints are most easily handled because they dry quickly. If the natural color of the wood is desired, white shellac is most convenient to use because it dries very quickly, provided the shellac is applied in thin coats. The ordinary varnish requires several days to dry thoroughly. An outside varnish should be used if the object is to be exposed to dampness or to the weather. For this purpose, spar or copal varnish is best.

Since there are so many books already published on the technique of woodwork, no regular discussion in processes and the use of tools is here intended. For the upper grammar grade, a forge, Machine
Tools. wood lathe, small machine lathe, and bench drill will prove to be a great advantage in giving the boys an acquaintance with a number of tool processes that are very desirable, besides making possible a greater range of problems.

At home, every boy should have his own bench. It can be fitted up with an iron vise screw costing about 50 cents. With Home Bench. a few boards, any ingenious boy can fit a bench up for himself. In working, care should be taken that the top surface of the bench is not sawed into or cut. To prevent this, a cutting board and a bench hook should always be at hand.

Every boy should have a few tools at home; such as a knife, ruler, gauge, saw, try-square, chisel, plane, and hammer. Measurements should always be laid off with the ruler held upon Care in the
Use of Tools. its edge. In laying off dimensions and in drawing lines, accuracy is highly important. A word of caution regarding the use of the plane is, *keep the cutter set so as to cut a thin shaving* when trueing up surfaces. On each piece of wood, secure a perfect working edge and end; and in laying out, always measure from them or from a center line. In surfacing the end grain of wood, plane from the edge, but never to the very edge, else it will split. To avoid splitting when using the auger bit, always set the work to be bored upon a flat surface of soft wood, or as soon as the point of the spur projects, turn and bore from the opposite side.

The use of the coping saw is a great advantage with thin wood. In laying out the work to be sawed, be careful to avoid short-grain construction. Where possible, always have the grain of projecting parts run lengthwise so that they will not easily break off. In putting a blade in the coping saw frame, set the teeth so that they point toward the handle. The cutting is done on the downward stroke. The sawing is best done on a V-shaped block fastened in the vise or to the top of a bench or table. The work should rest flat on this block. The saw should have free play up and down about two strokes per second. If the work is not held down firmly, the saw blade will be bent or twisted and this will cause it to break. When turning a corner keep the saw going up and down at a good rate of speed at the corner to be turned, and at the same time slowly turn the work around into the desired position. Of course, the saw must be kept at right angles to the work at all times.

Never use dull tools. With the use of oil and an oil stone a true mechanic and craftsman always keeps tools in working condition. Lastly, I would say that the three essentials for satisfactory work are *common sense, carefulness, and accuracy.*



Fencing. Fencing Rods, Work of Seventh Grade Class,
Durham, N. C.

(*Photograph by Author*)



Correlation of Nature-study and Manual Training. Pittsburgh Vacation Schools, Pittsburgh, Pa.
(Photograph by Author)

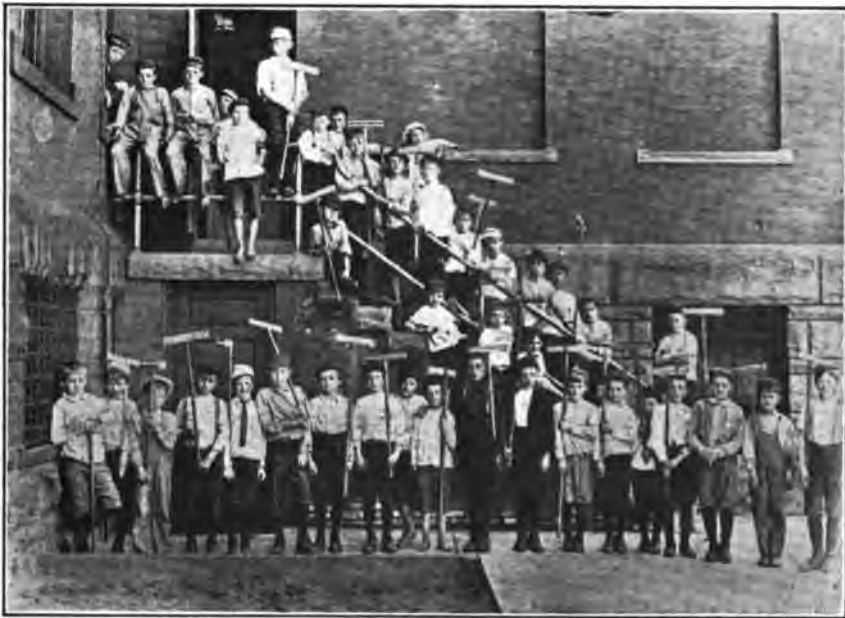

Garden Tools Made and Used in One of the Pittsburgh Vacation Schools
(Kindness of Mr. J. Thompson)



**Cultivation of the Constructive-Play interest leaves no room for the Destructive-Play tendencies
Manual Training Play affords rich opportunity for mental, spiritual and physical development**

**MANUAL TRAINING—PLAY
PROBLEMS**

**CONSTRUCTIVE WORK FOR BOYS AND GIRLS BASED
ON THE PLAY INTEREST**



TOPS. Tops may range from the crude primitive ones used by the Indians, to the wonderful gyroscope. The usual methods of spinning the simpler ones are by means of the thumb and finger, the palms of the hands, and the whip cord. Fig. 1 represents the simplest kind of a top made from an empty spool. Fit a dowel tightly into the hole at the center of the spool, cut the inside bevel down to the center, and the top will be ready for service. A round-headed tack or escutcheon pin may be used at the point for a plug. If it is desired to use a cord with this top, make a holder for it as suggested in Fig. 2. Bore a small hole in the middle of the stem to insert the end of the cord. This will catch the end of the cord and prevent it from slipping around the stem when beginning to wind the top. Wrap the cord with the holder in position on the stem of the top. To spin the top, place it in position and with one hand grasping the holder pull the cord, after which slip the holder off the stem.

Many interesting variations can be worked out. An outline profile made of wire can be made as suggested in Fig. 4. The straight end of this wire can be slipped into a hole bored into the end of the stem. The rapid movement of the top will give to it an oddly interesting appearance. Studies in color combination can be made by placing colored papers on the upper surface of the disc. See Figs. 1 and 3. Tops made of sheet metal can be made to produce a variety of humming sounds by means of openings cut into the surface of the metal. With the wooden top this humming is possible to a very limited extent only.

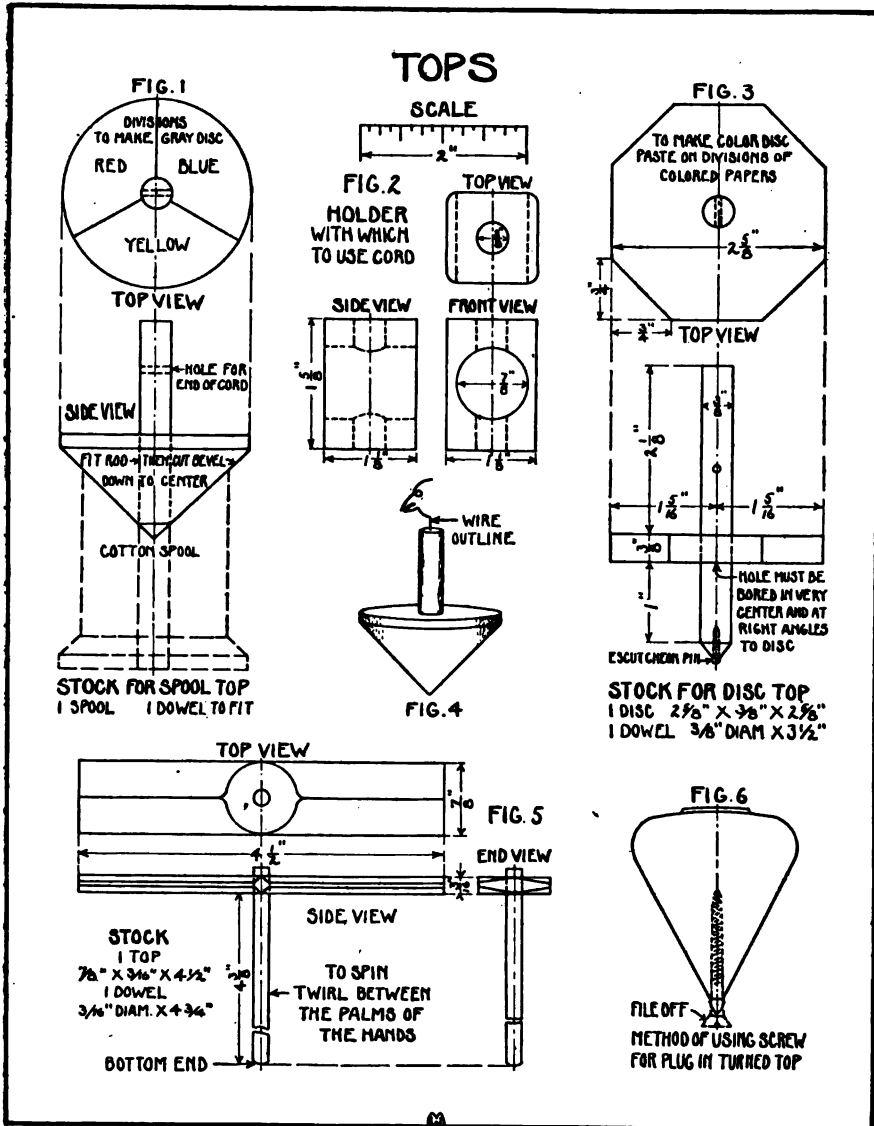

Fig. 5 looks like a butterfly (page 7); but, when twirled between the palms of the hands, drops to the floor and spins in an upright position. The ordinary peg top must be turned on a lathe. A screw is used for the plug, and the head filed off. See Fig. 6.



CIGAR-BOX FURNITURE. See page xxi for general suggestions on furniture construction.

There are innumerable possibilities in furniture made of cigar boxes. The top of the table shown in Fig. 1 is made from one half of a cigar box sawed in two lengthwise. The four corners of the remaining half of the box are used for the legs. If a table with a projecting top is desired, the lid of a box somewhat large can be nailed on top of this as shown by the table in the top row of the above photograph.

The davenport as shown in Fig. 2 is made by sawing a box in halves lengthwise and fastening the two halves together with the edge surfaces facing each other.

The rocker cradle as suggested in Fig. 3 is simply made by fastening on end pieces cut to the rocker shape. If desired, the rockers can be made to fit around the box and fastened underneath.

The washstand as shown in Fig. 4 is a type of pieces suitable for bedroom furniture, wherein the box is taken whole and additional pieces such as top or uprights fastened on. A few of such pieces can be seen in the photograph. With little modifications most of the different pieces of furniture, as well as innumerable other problems, can be made from cigar boxes of various sizes.

In the photograph on the lower row, the paper is shown left on the boxes. If the pieces are not to be painted, the paper should be scraped off after the cutting is finished. This wood splits easily even

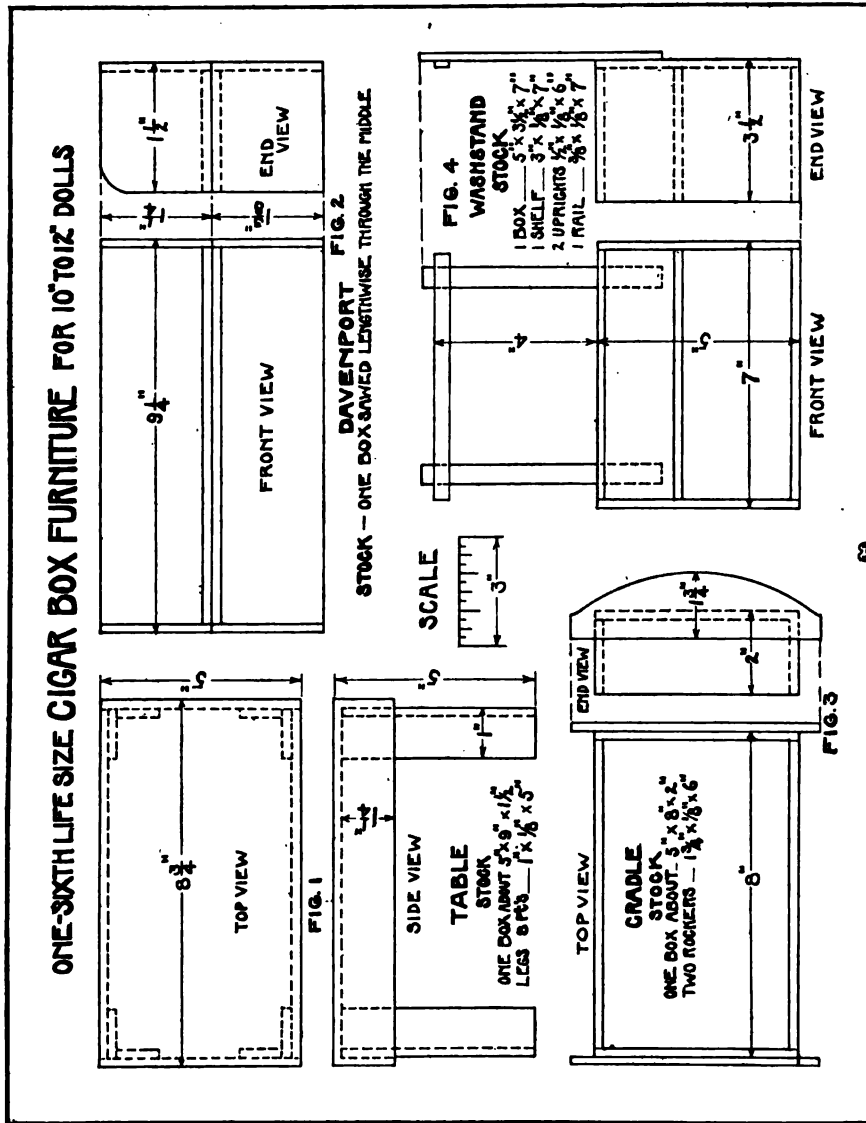

when worked with the coping saw. The paper strengthens it considerably. For this reason it is well to do all cutting first. When dampened the paper can readily be scraped off. If the box is to be painted or varnished, let it dry before applying.



BUTTERFLY AND WHIRLIGIG. The top or wings of these problems may be made of wood, cardboard, heavy tin, or thin sheet iron. The most successful flyers have been made single as shown in Fig. 1, but with a cross-lap joint they may be made double as shown in Fig. 1 of the windmills on page 35. One of the essential elements of the butterfly is its lightness. The wings made double afford an excellent problem in a cross-lap joint of wood, but the necessary wood required in lapping the joint is apt to make it rather heavy. If made of tin or sheet iron, the two pieces should be crossed and fastened together before piercing the hole through the center and fastening with a small nail to the end of the dowel.

Fig. 2 and the photograph give the necessary information for making the whirligig. The whirligigs shown in the above photograph have been flown over the top of the schoolhouse three stories high. This may be made, also, with double wings, as already suggested. On account of the power possible to be obtained from the string and spool, the added weight of the cross-lap joint is less objectionable. A small piece of wood $\frac{3}{4}$ " square can be rounded up for the handle and a round rod or dowel slightly smaller than the hole in the spool should be inserted into one end. Drive small nails into the projecting end of this dowel and into the spool and cut the heads off. Make holes in the top piece to fit over these nails large enough to allow it to slip off easily. Notice that the ends of the top pieces are bent or beveled in opposite directions to each other. For the top or wing to fly off

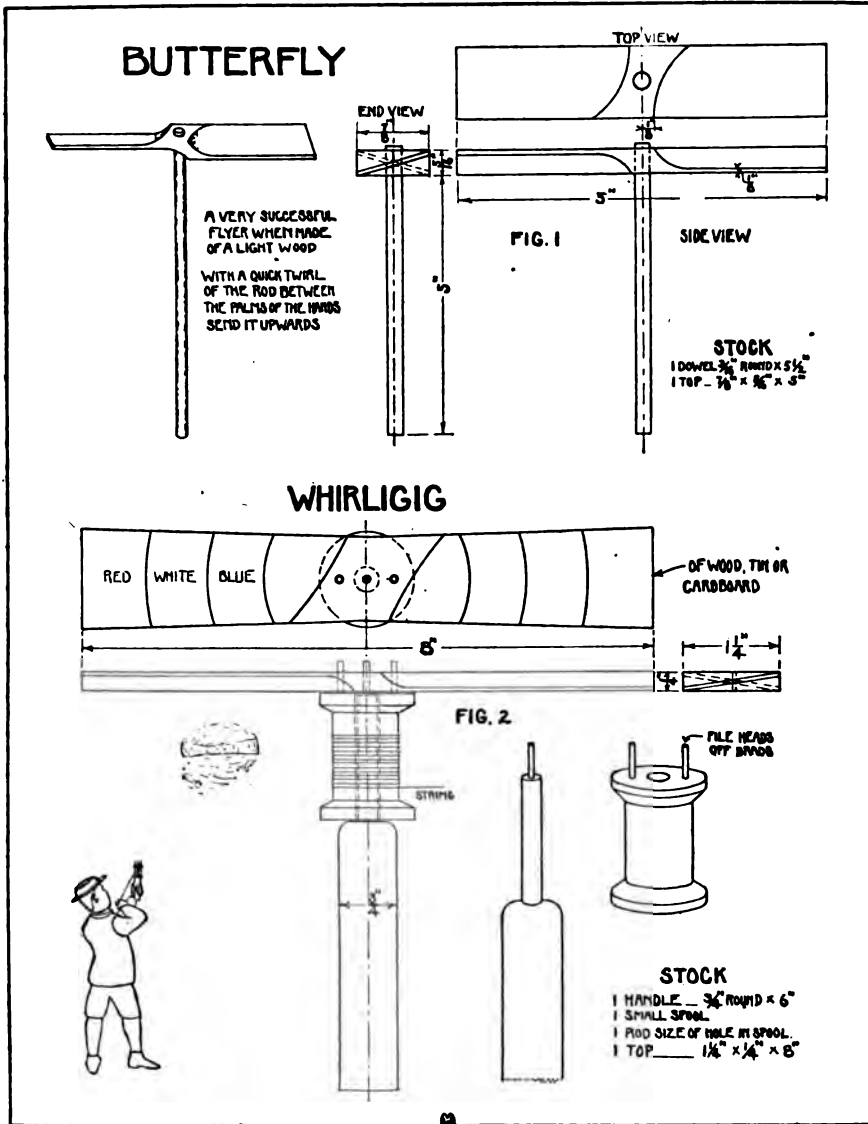

when the string is pulled, it must be wound so that the action of the air will force it upward. Alternating stripes of color applied to the top piece add much to the attractiveness of the flyers. Flying contests create interest in the use of various materials and in good construction.

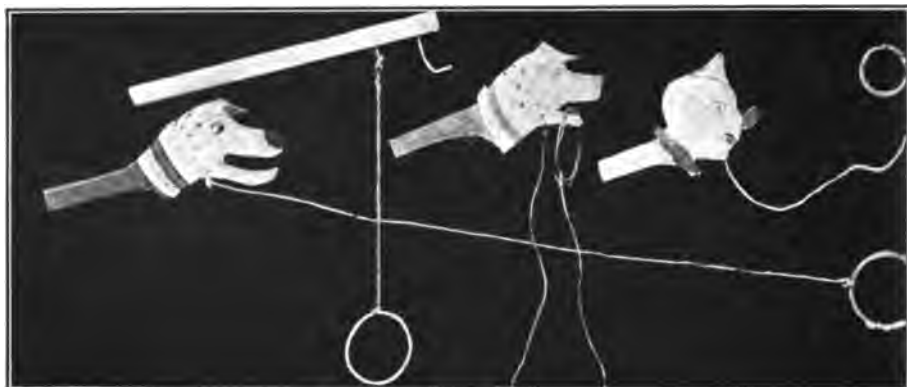

RING TOSS GAMES. The object of this game is to toss the ring in the air and catch it on a hook fastened to the end of a stick. The simplest form is shown in Fig. 1. Use a large-sized screw, hook, and cord about two feet long. Make the ring of wire, reed, raffia, cardboard, or heavy cord. For rounding the handle see pages 60 and 61.

Other interesting arrangements involve forms which can be sawed out with the coping saw, such as those shown in the photograph. The wire used for the ring should be about $\frac{1}{8}$ " in diameter. Coloring adds much to the interest of such figures. If the lathe is available, this game might be worked into a cup and ball arrangement, the ball taking the place of the ring, the object being to catch the ball in the cup; or a small net might be fastened to the end of a stick, the object being to catch the ball in the net. Fig. 3 has been suggested by Henry Turner Bailey. Here is his description of how a boy of his acquaintance made one: "He had taken a barrel head and nailed cleats across to hold the pieces together. He had covered the smooth side with a piece of brown paper on which he had drawn a six-pointed star, using a string, he told me, to get it right. Into this star at the center and at the angles he had driven long, slim wire nails; and with a pair of pliers he had bent up each head-end at right angles with the rest of the nail, making hooks like L's driven head first into the board. Under the center nail he had printed 100. The others were numbered as you see in the sketch. This circular board was hung on the outside wall of the house. We stood about 10 feet away and pitched rings

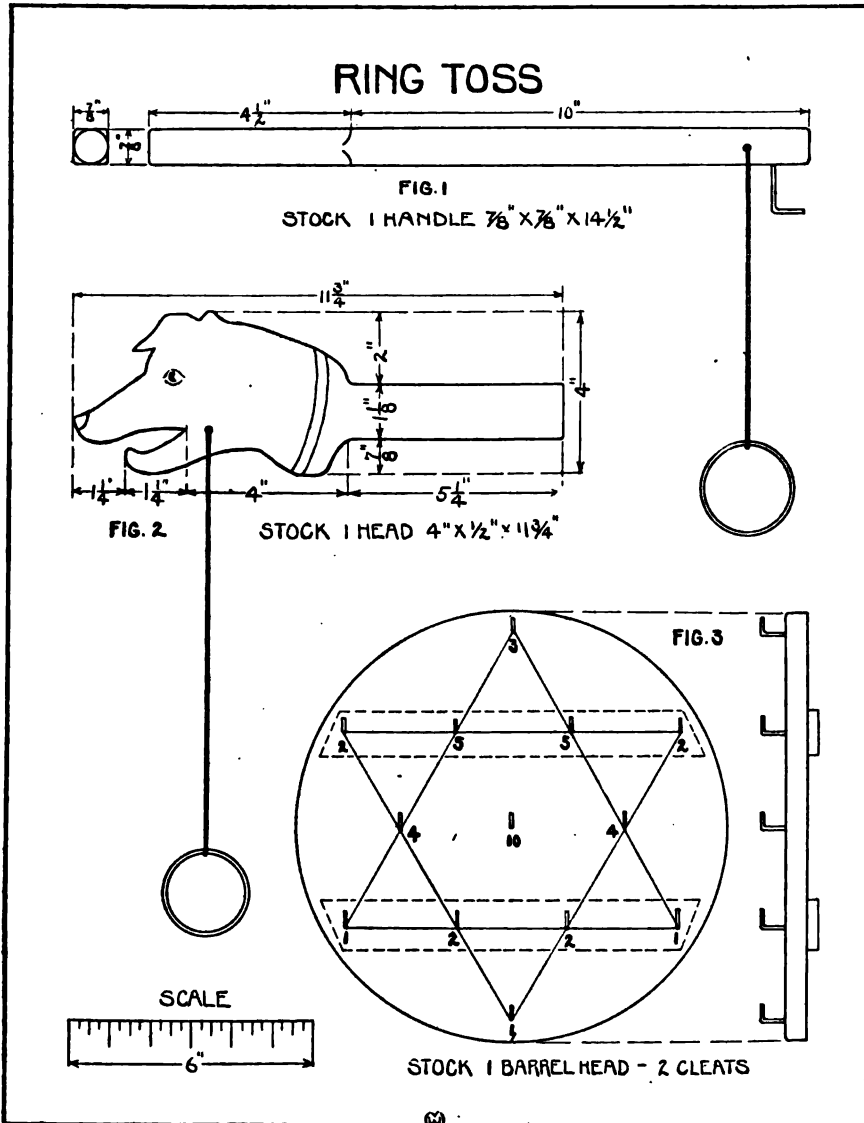

at it to see how much we could make. What sort of rings do you suppose? Rubber rings! Rings from off his mother's preserve jars."¹

(Note: The above scale has been reduced one-tenth of the original.)

¹ *School-Arts Book*, January, 1908, p. 439.

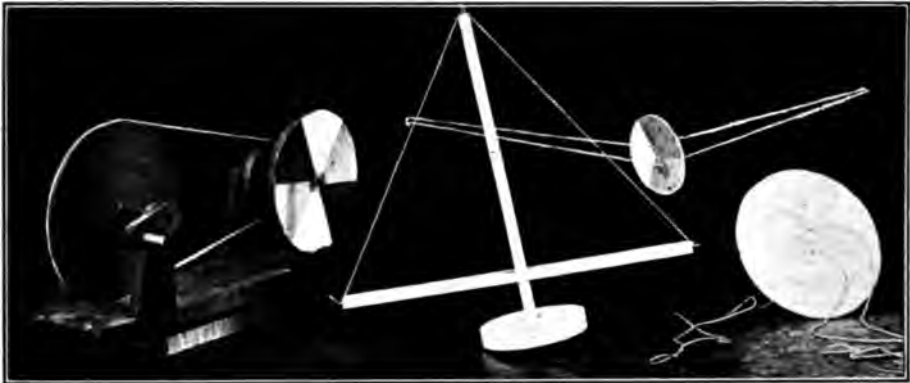

BUZZER — PRIMITIVE DRILL. Every boy is familiar with the buzzer. In the school workshop it can be made the first lesson in whittling. Fig. 1 is a disc of wood or metal in the center of which are punched two holes into which a cord is slipped. Fig. 2 is a similar arrangement in which a rectangular strip of wood is used for the disc. A color disc can be made by pasting colors on the sides; for instance, semicircles of blue and yellow when put in motion will produce green. An irregular edge on the disc or holes pierced in the disc near the outer rim will produce whistling sounds.

Fig. 3 is an Indian string drill. A rod is fitted securely into one end of a round disc. This disc, when set in motion, is the balance wheel which supplies the necessary momentum to the drill. Into the center of the end of the rod is fastened a drill point which can be made of a piece of steel wire, a hat pin, or nail. A hole slightly larger than the diameter of the rod is bored into the center of the horizontal strip.

To string the drill, bore holes at each end of the horizontal strip. Then slip the cord through the hole in the rod and fasten the ends of the cord to the ends of the horizontal strip as shown in Fig. 3. In the photograph it will be noticed that nails are used to fasten the cord. The holes have been found to be more satisfactory.

To work the drill, place it in position and set it going by spinning the disc with the hand. This will twist or wind up the cord around the rod. As soon as it is wound up, press down firmly on the horizontal strip, pressing down as soon as wound up, which will cause it to un-

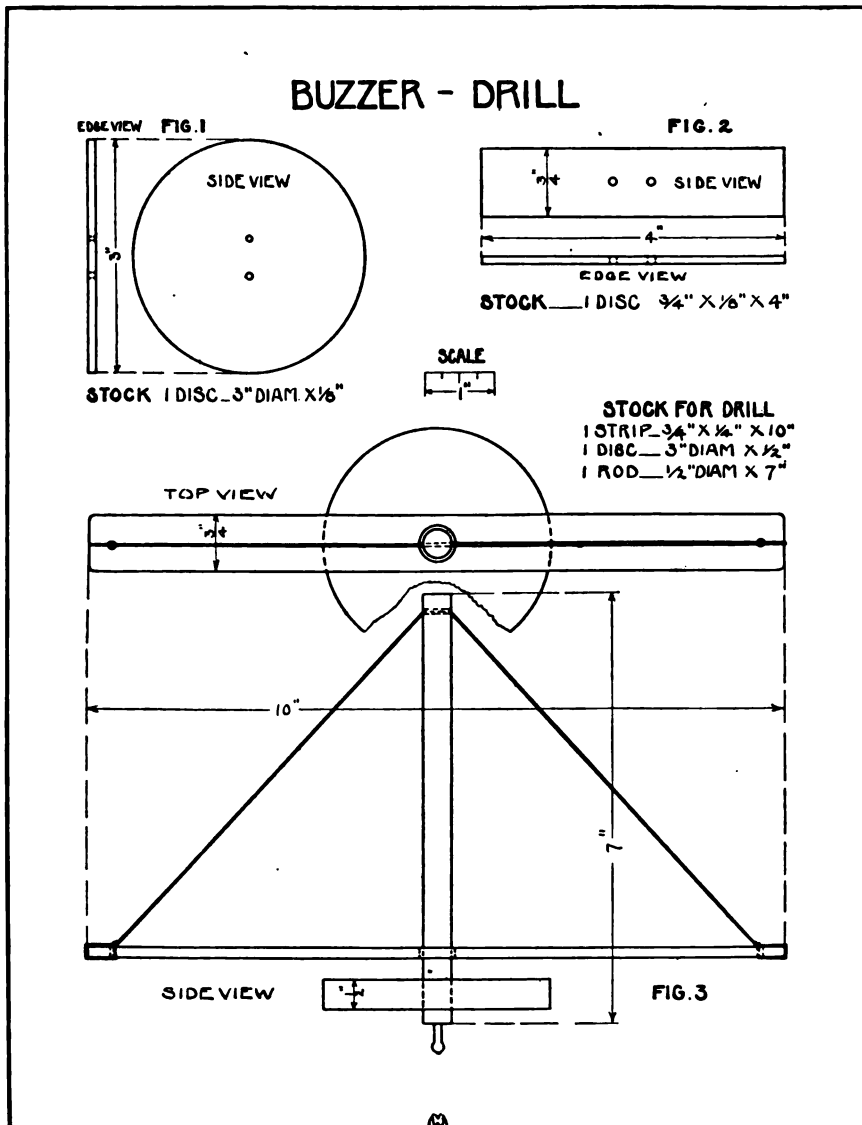

wind and spin in the opposite direction. As soon as it is unwound, relieve the pressure on the horizontal piece and the momentum of the piece and the disc will cause it to wind itself up again. By thus repeatedly pressing and relieving the pressure, the drill is kept continuously in motion.

GARDEN SIGN — TRELLIS — STICK — LABEL. The garden signs are very convenient for indicating the numbers or owners of the garden plots. The sign board or crosspiece should be painted or labeled before fastening it to the upright. A thin coating of white shellac



or filler should be applied to the sign board before painting on the letters to prevent the paint from running. If the sign is to be permanent, to withstand the weather from year to year, a coat of spar varnish should be applied after the lettering has dried thoroughly.

The upright of the trellis (Fig. 2) should be made of perfectly straight grained wood. Divide the $1\frac{1}{2}$ " width into four equal parts by gauging the lines apart. Saw on these lines within 6" of the end. Spread the strips thus made, and hold them apart with a crosspiece as suggested in the drawing. Any number of strips as desired can be thus made.

The kind of trellis suggested in Fig. 3 and the photograph can be made with one or more uprights and any number of crosspieces. At least two nails should be put in each joint and these should be

firmly clinched. In each case the crosspiece should project somewhat beyond the uprights.

The plant stick should be made long and heavy enough to suit the intended use. There should be one or more notches at the top end to hold the string in position. The problem as suggested admits of quite a number of elementary tool exercises.

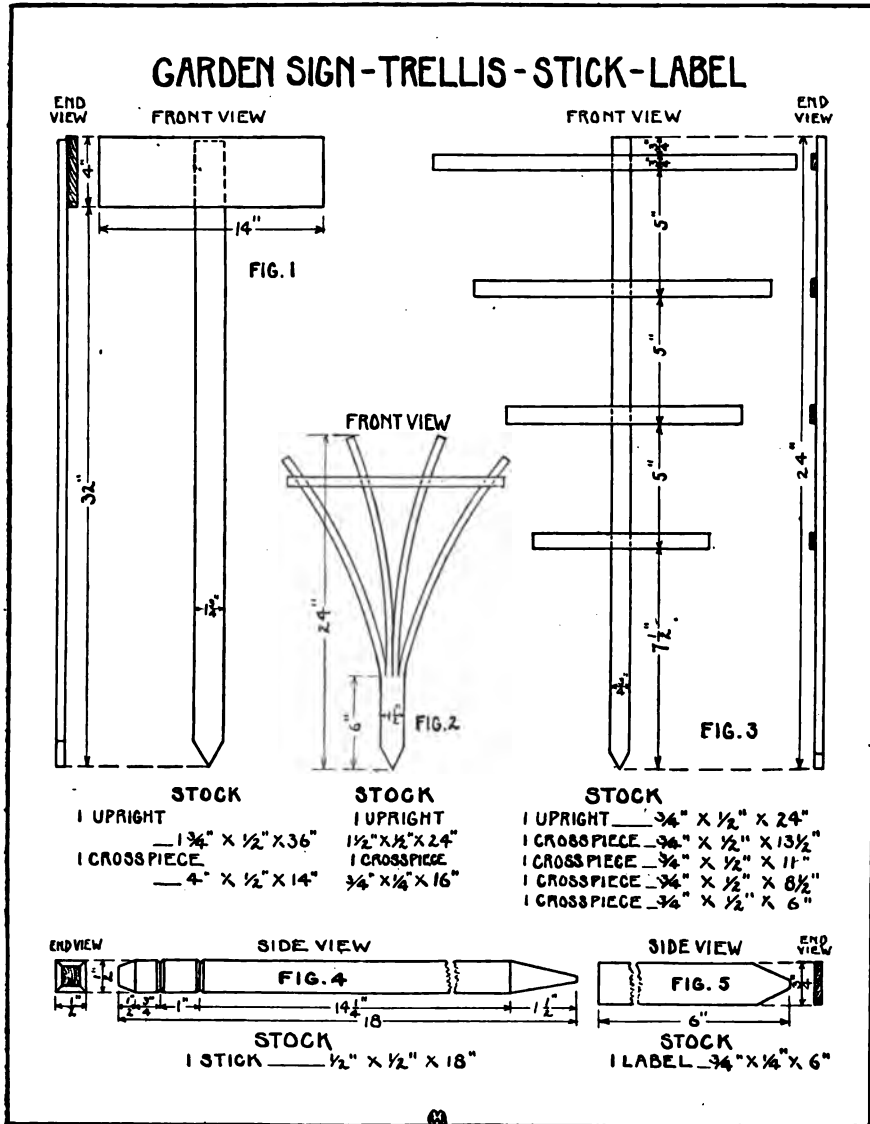

The name of the plant can be printed on one side or on both sides. The seed or plant label suggested in Fig. 5 is a suitable problem for beginning knife work. If made longer and notched at the top end, it can be used as a plant stick also.



KALEIDOSCOPIES. A very simple form of kaleidoscope is shown in Fig. 1. Long narrow panels of glass should be used, as length multiplies the reflections and thus produces a more effective kaleidoscope. Mirror glass is best, but ordinary window glass will do. Tie them into a triangular shape as shown by the second figure in the photograph. Next cover the outside of the glass triangle with a dark cover paper. Seal one end up with tracing cloth or a tough tracing paper. Stand on end with the open end at the top and drop in bits of colored glass, or other particles. Lastly, paste a piece of opaque paper over the open end and punch or cut out a little peep hole. Hold so that light will penetrate from below through the tracing cloth or paper.

Fig. 2 has a revolving end, as shown in the photograph. Select a long tin can and punch a small opening in the bottom for a peep hole. Cut glass to fit inside the can. To improve the reflecting power of the common window glass, blacken with smoke or paint on one side. To hold the glass in place, wedge a cork back of the strips of glass. Cut a large opening into the end of the lid of the can and cover this opening with a disc of glass or tracing cloth. The frosted glass for this is most desirable. The frosted effect can be produced by rubbing on a paste made of whiting. Fasten this disc securely in the lid. On this glass drop bits of colored particles. Now put the lid in place on the can and turn it upside down. By revolving the lid with the can stationary, an ever changing panoramic effect is produced.

Fig. 3 is a "duplicator." It is much used by designers. To con-

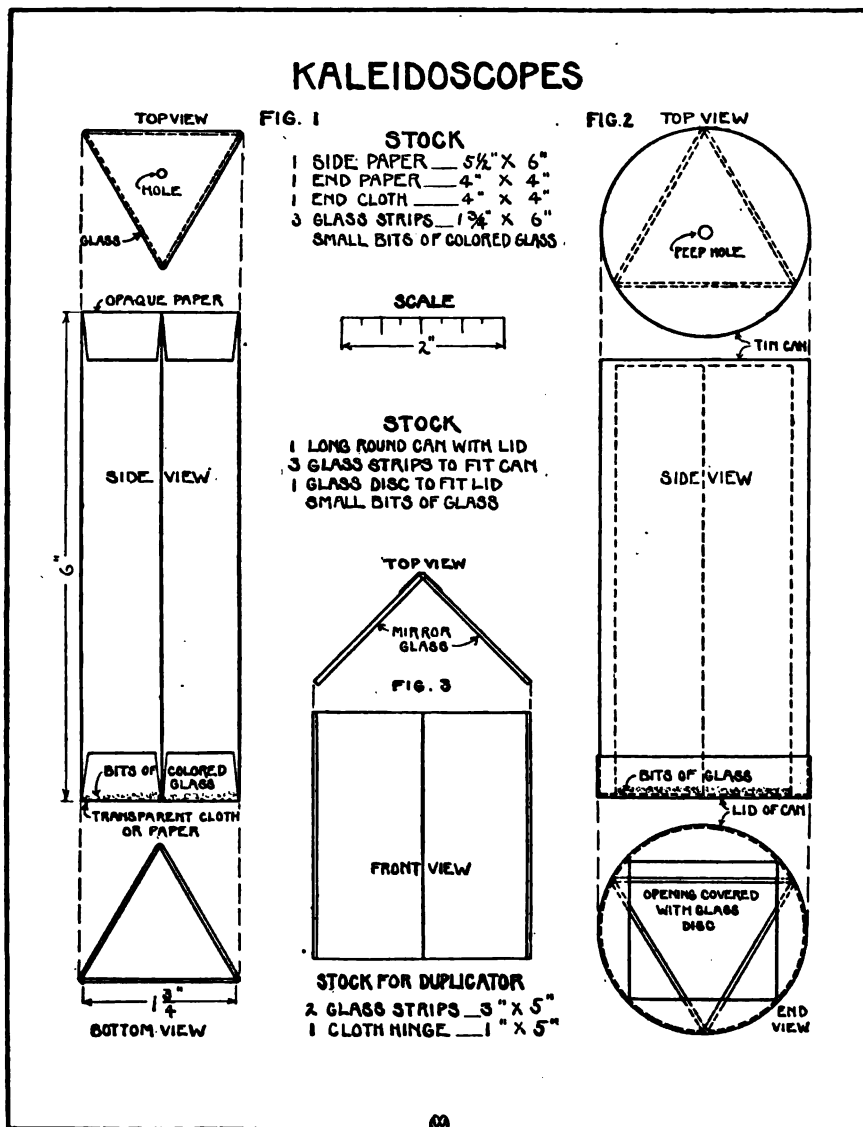

struct, fasten two pieces of mirror glass together with a piece of gummed cloth or tape. To use, set it on end with the two mirrored surfaces at right angles placed around the design to be used. With this double mirror a design can be made to multiply itself four times.

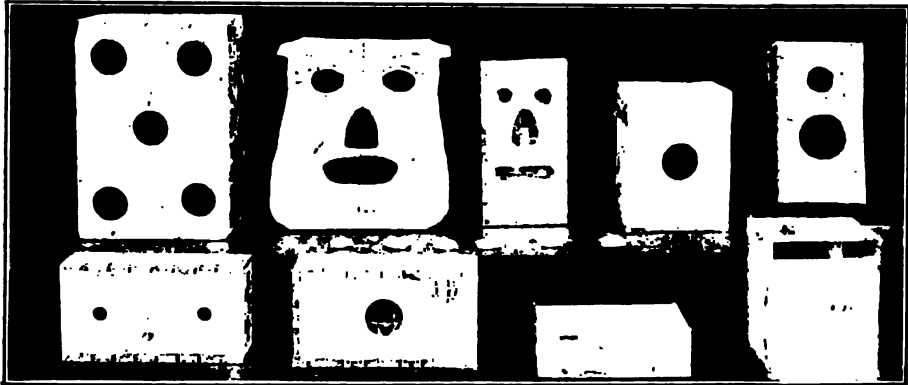

BEAN BAG GAMES. For bean bag games, hoops of various sizes can be fastened together, one within the other in concentric circles; or boxes of various sizes can be fastened one within the other. In such an arrangement the throw which places the bag in the smallest or middle hoop or box receives the highest count.

Animal and human figures add considerable interest to the game, such as: the figures of persons holding in their outstretched hands discs, squares, or objects represented by openings; or the eyes, nose, and mouth cut out of a board as suggested in Fig. 1.

To make the board suggested in Fig. 1, select two pieces the proper length and half the required width. Fasten the two pieces together with two brads or a handscrew so that it is possible to cut out both sides by sawing through the two thicknesses at the same time. Cut the openings, and trim to the outline. Take the two pieces apart and fasten in position with three battens, one between the nose and the mouth to strengthen this part which otherwise would break off. To hold the board in an upright position, a rest or leg can be attached to the back by means of a strip of leather or cloth used as a hinge; or a nail or wire can be used as a pivot as shown in Fig. 1.

In the lower row in the photograph is seen a box in which is a wire fastened lengthwise. One or more wooden figures are put on this wire so as to revolve upon the wire. The object of the game is to strike one of the figures and thus make it revolve. Another arrangement shown in the lower right-hand corner of the photograph is a box

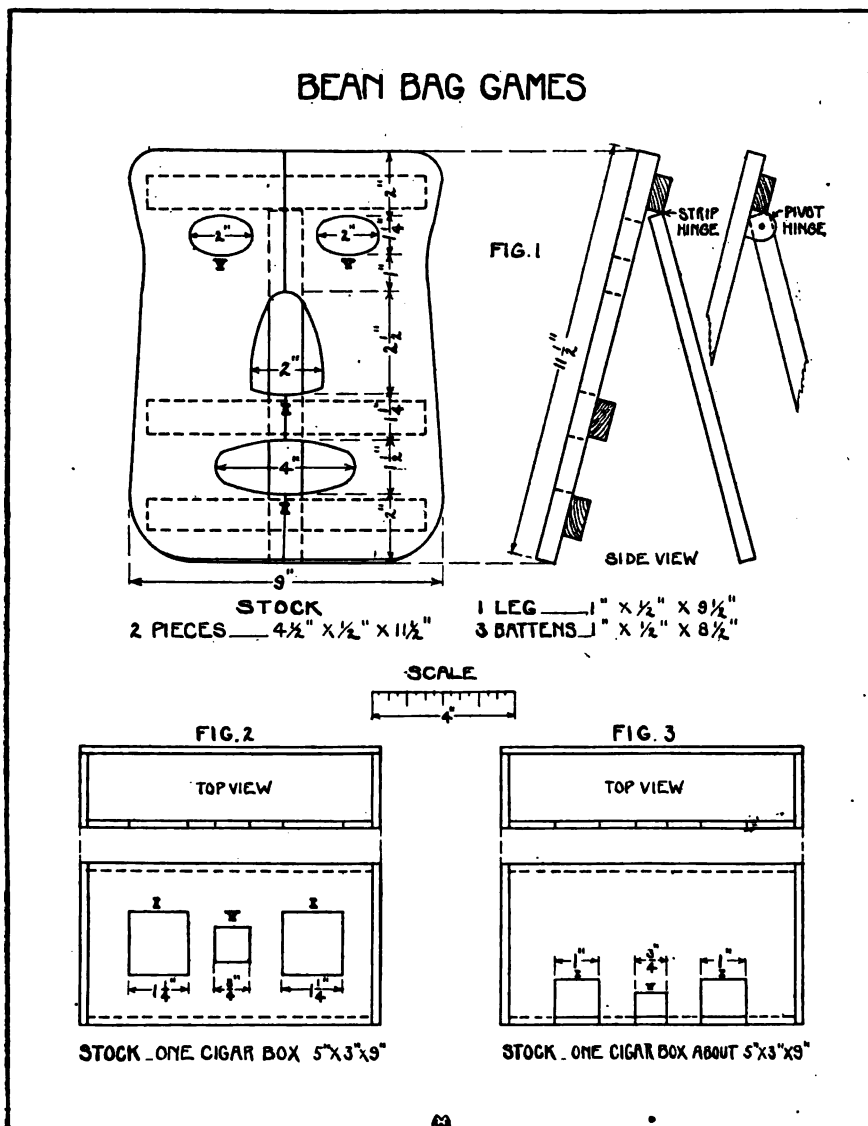

with a sliding cover. By means of this sliding cover the opening can be made any size desired.

The bean bags should suit the openings. The ones shown in the top row of the photograph were made 1" square, to use with Fig. 1.



CHAIRS. See page xxi for general suggestions on furniture construction. The type of work herein suggested, if properly made, will stand much rough usage. The seat part should be fairly thick and requires careful work in boring. The holes should be bored until the point of the bit begins to come through. The ends of the pieces that fit into the wood should not be tapered, but should be trimmed round so as to make a perfectly snug fit. They should be fastened in place with glue and brads. For the backs and the legs of the chairs, scraps of trimmings can be used. If a rustic effect is desired, use twigs of wood with the bark on. The holes for the legs should be bored so that the legs will slant outward in both directions. The ends of the legs should be slightly rounded or chamfered so that the edges will not split when pushed across the floor. The back strips of the chair such as in Fig. 1 should be fastened together with two nails in each cross-lap joint. Use nails in these joints long enough so that the ends can be turned and clinched firmly.

This type of construction can be used in many other pieces of doll furniture such as tables, taborets, and beds. By making the seat longer, a divan such as is shown in Fig. 2 can be made. By leaving off the back, a stool can be made such as shown above. If a table is desired, it must be made proportionately larger. Make it the desired width and length, and 5" high instead of 3". It must be borne in mind that this type of construction cannot be applied to the larger size pieces of furniture, because it is not practicable to have the seat

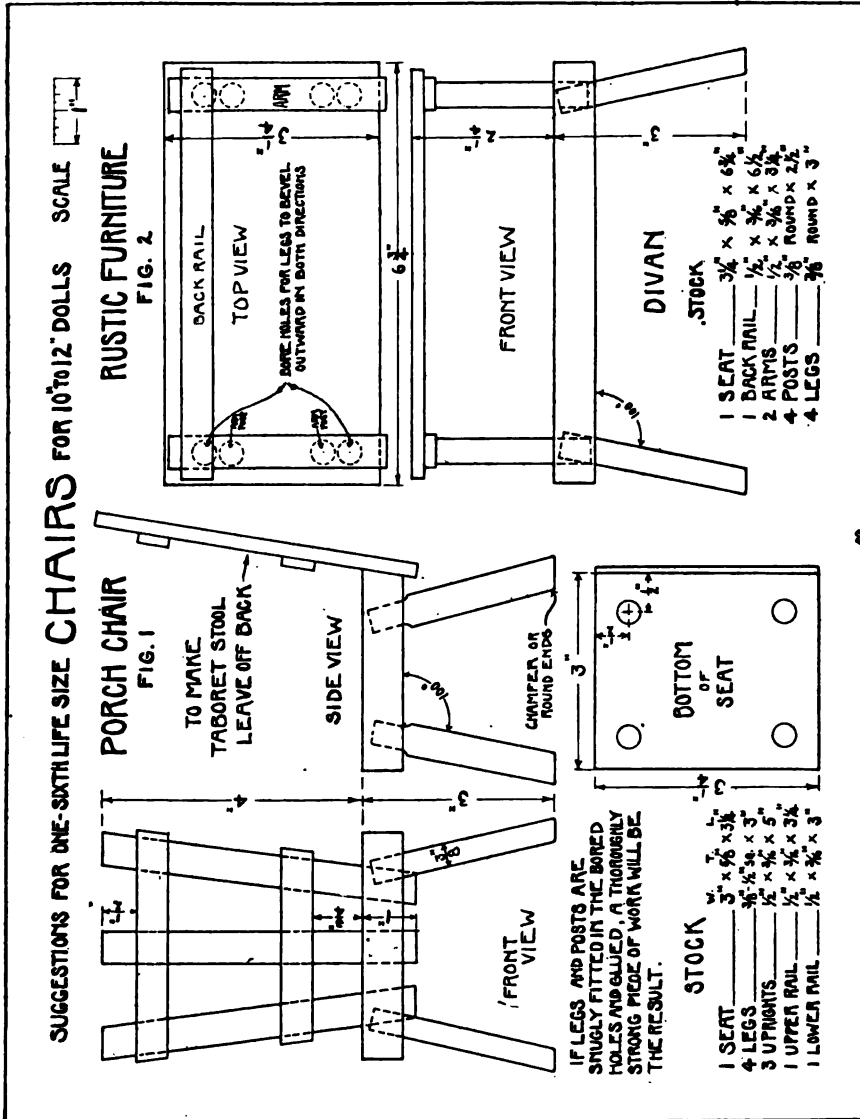

proportionately as thick; and a more thorough bracing is needed because of the greater strain proportionately made upon the larger pieces of furniture. And, too, it must be remembered that the children demand things made quickly, else they will lose interest.

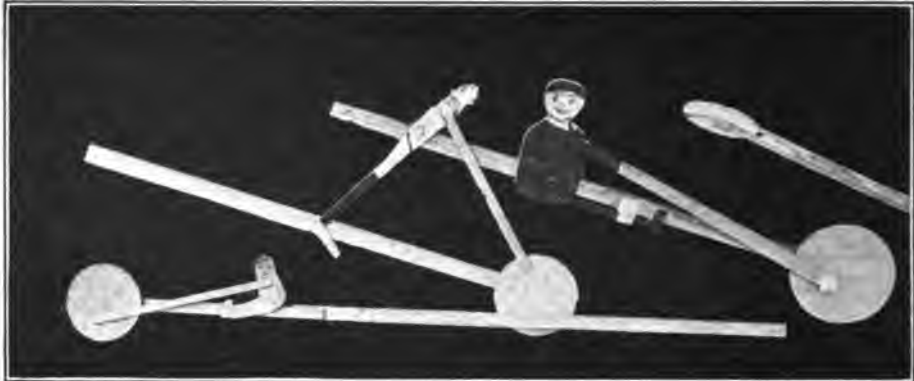

RUNNING WHEELS. Many ingenious lever and eccentric types of running wheel can be constructed, a few of which are illustrated in Figs. 2 and 3 of the opposite drawing, and also the drawing on page 25. With these problems opportunity is given for the study of mechanics of the lever and eccentric. The long-armed Goo-goo jacks afford an interest to the younger children which is very desirable to the manual training teacher.

If coping saws are not available, the figures can be cut out of cardboard and glued or tacked on, as suggested in Fig. 2. If cut out of wood by means of coping saws, definite limitations of size and shape are necessary so as to obtain good proportion and to avoid short grain. Boys can work out their own individual modifications of the figures. These are best cut out of paper with scissors first and then traced around on the wood. If time is limited, the teacher can work a few forms out of heavy paper or thin wood and allow the pupils to use them as templates.

The simplest running wheel is made of a round disc of wood or metal for the wheel with a broom stick for a handle. A groove is sawed in the end of the stick, as shown in Fig. 1.

For the arm to revolve properly, the distance between the pivots on the body must always be somewhat greater than the distance between the pivots on the wheel. In making the holes for the pivots bore with a small drill or drive the nail in very carefully, else the thin wood will split. For further directions for this work, see page xix.

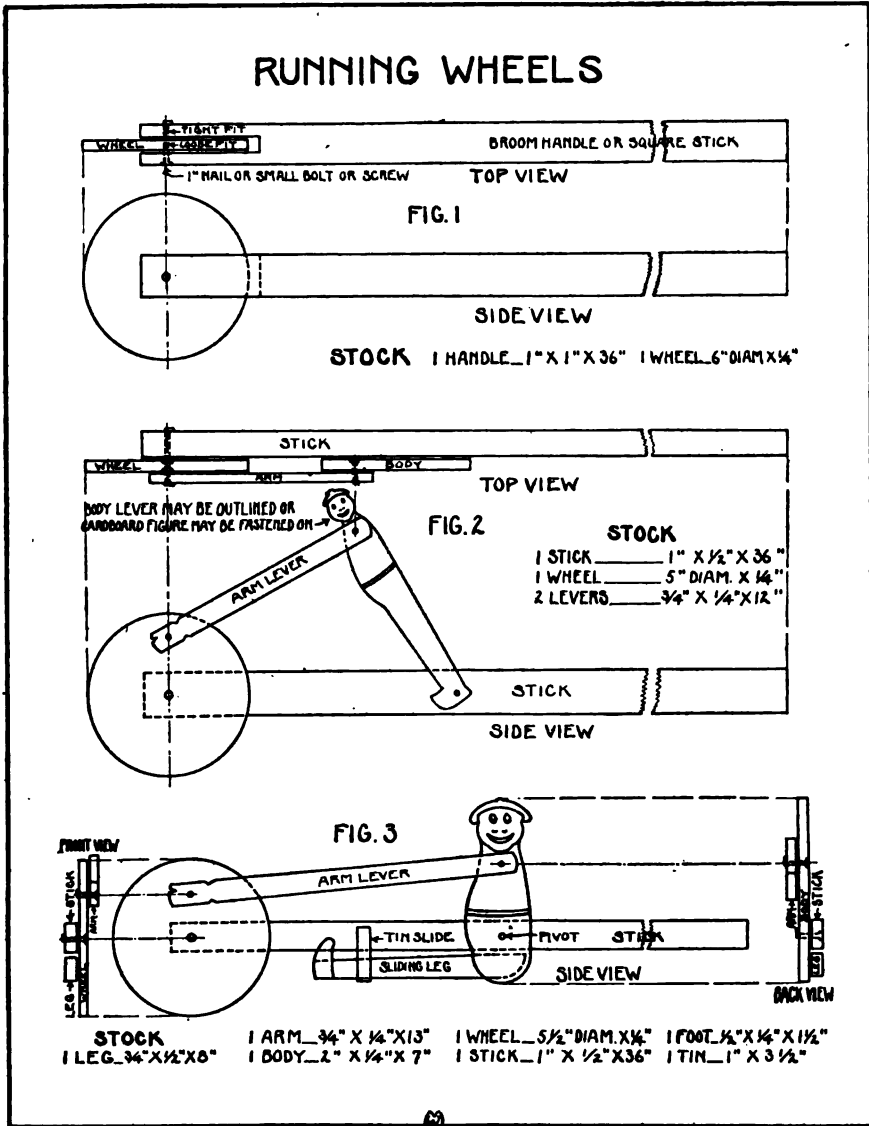

The sliding leg, as in Fig. 3, must not be fastened close up against the edge of the stick, but a space of $\frac{1}{8}$ " or more must be allowed.

For further directions as to construction of running wheels, see Running Wheels, pages 24 and 25.

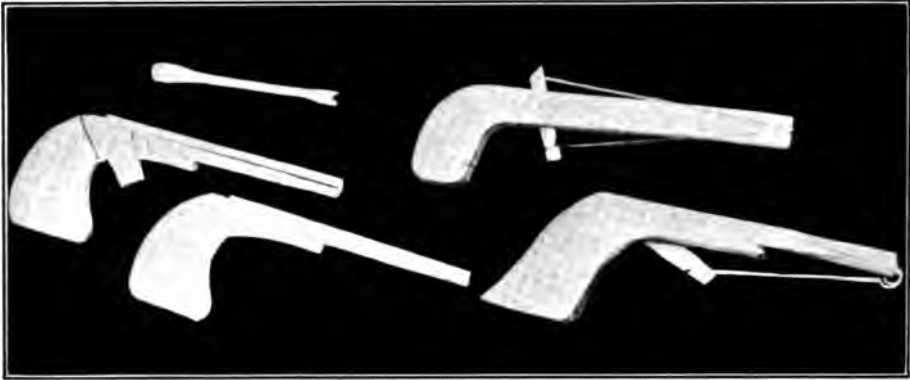

PISTOL AND SLING SHOT. Fig. 1 is made by taking three thin pieces of wood about $\frac{3}{16}$ " thick, the desired length and width. Fasten them together by means of a brad at each end. After sawing the outline, take the pieces apart and saw a part out of the middle section so that, when the pieces are put together again, a groove is left in the barrel and a slot is formed so that the trigger can be set in position. The side view of Fig. 1 shows the trigger in position. It should be very slightly thinner than the thickness of the middle section, but not free enough to drop down loosely. After the pieces are fastened together, the trigger should be pivoted in place with a nail.

The rubber band is fastened to the end of the barrel by means of a brad which is bent over far enough to lock the rubber band in place. To cock the pistol, pull the rubber band back so that it is held by the notch just above the trigger.

If the stock and barrel are to be made of one piece instead of three, the slot for the trigger must be cut out with an auger bit and chisel. The groove of the barrel should be cut out half-round or square.

Fig. 3 is a trigger in which two rubber bands are used, as shown in the upper figure of the photograph. Take care that the upper end of the trigger does not project up too high, else the rubber will lie too close to the top of the barrel.

The shaft or arrow (Fig. 2) should be made to fit in the groove of the barrel. The rear end should be slit and a paper rudder inserted. The forward end should be weighted slightly. A small brad driven

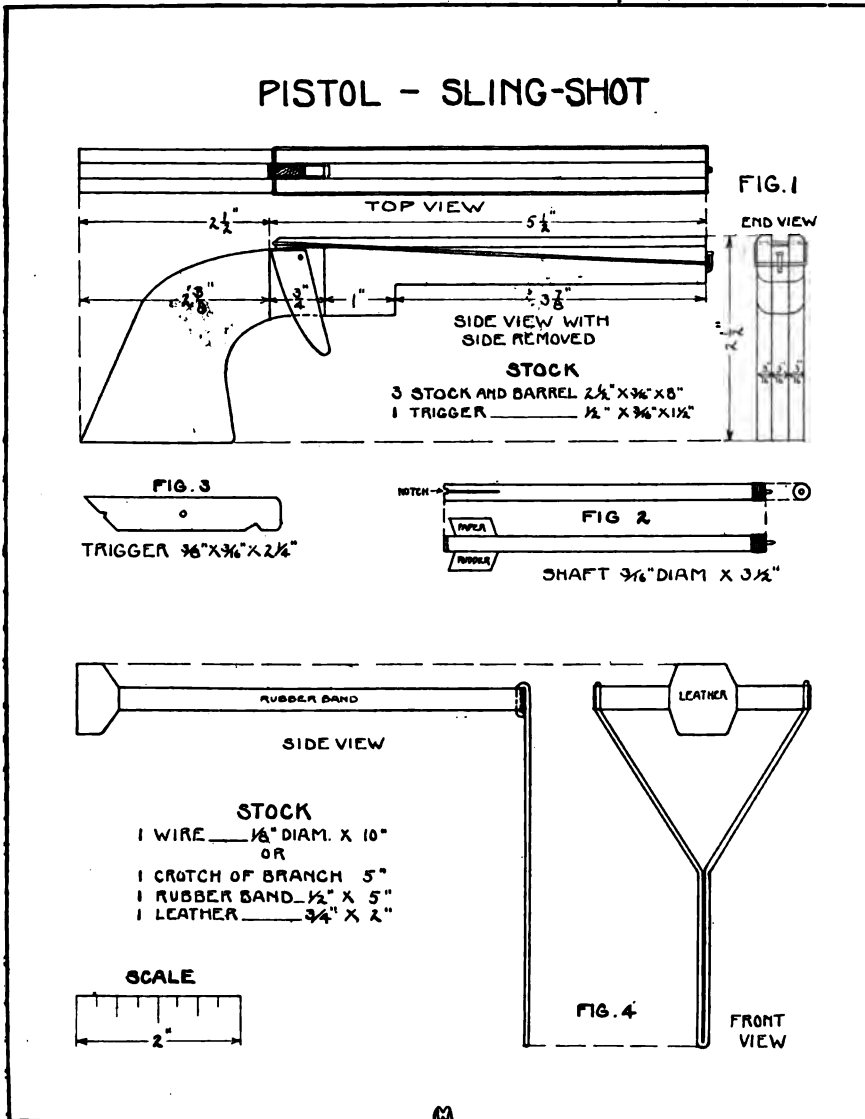

into the end will enable the arrow to stick into the target. To prevent the end from splitting, wrap with fine wire. The wire and brad will be enough weight for it to carry itself head foremost. The rear end must be notched slightly to catch the rubber band.

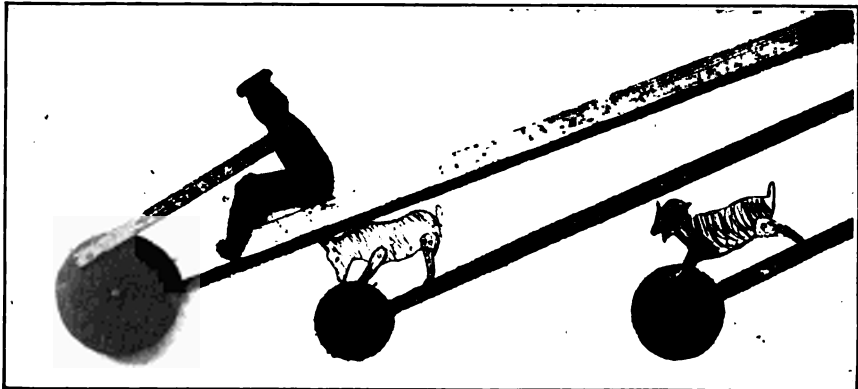

RUNNING WHEELS. Figs. 1 and 2 are long-armed Goo-goo jacks that continuously turn around the wheel as it runs along the ground. In Fig. 1 the leg which is made in one piece can be fastened to the stick, or it can be pivoted at the foot and a block fastened to the stick to keep it from falling. In Fig. 2 the jack sits on top of the stick. If a simpler construction is desired, the body can be made as wide as the stick; and in this case the leg can be made in one piece. In the drawing the leg is made of two pieces which pivot at the knee. A washer is also needed at the shoulder so as to bring the arm on a line with the outside of the wheel.

Two pivots are always necessary on the body, one at the hip and one at the shoulder. The distance between these two pivots must be somewhat greater than the distance between the axis of the wheel and the pivot of the eccentric.

In fastening together it is well to have the parts in position, as shown in the drawing. Note that when the stick is in a horizontal position the pivots on both body and wheel are directly above each other.

For the axis of the wheel a small bolt is very desirable, but a wire or common nail with the end bent over is satisfactory. If a bolt is used, the end of it should be hammered to upset it a little so that the nut will not slip off and get lost. A small metal washer or burr between all joints that pivot is desirable. Grease or wax will also help reduce friction. All the parts that pivot must be slightly larger than the diameter of the wire on which they turn. See page xx.

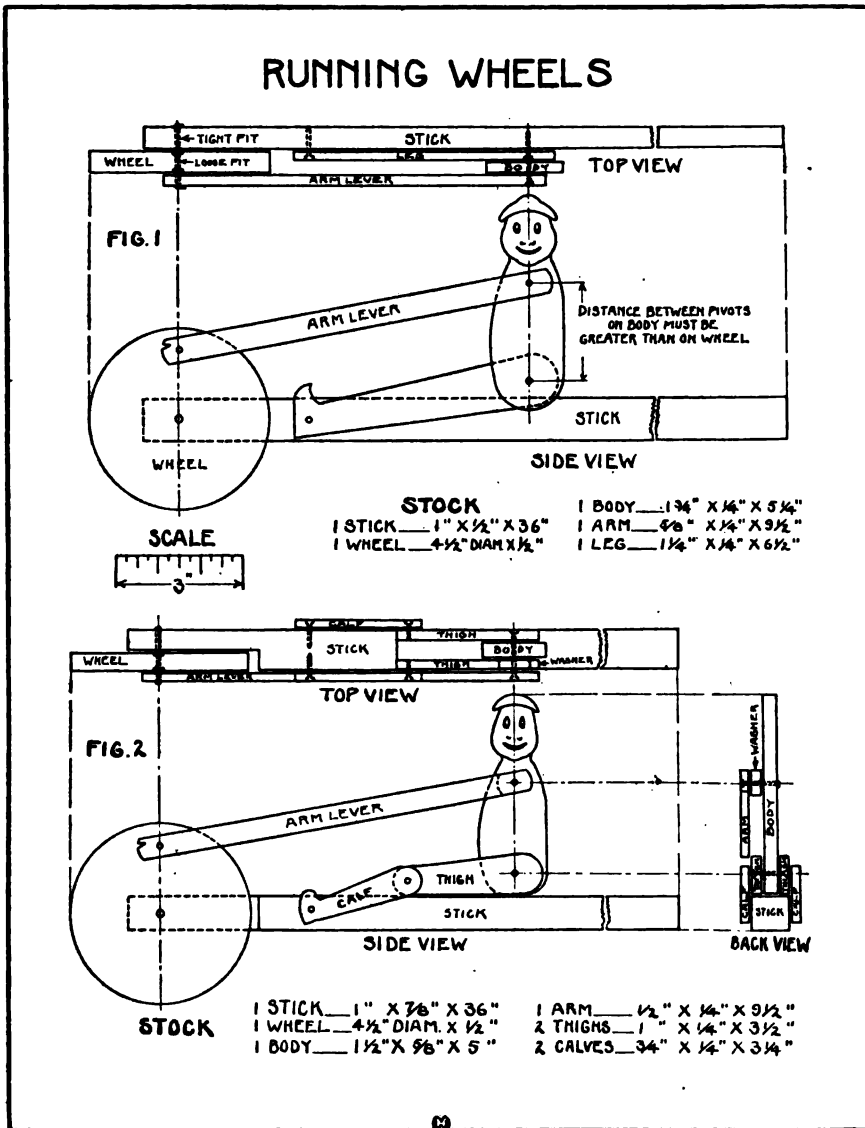

Before fastening the parts together, paint with bright colors to add to the attractiveness of the wheel. The ones talented in drawing can paint the facial expressions, or printed designs may be cut from cards or the pages of magazines.

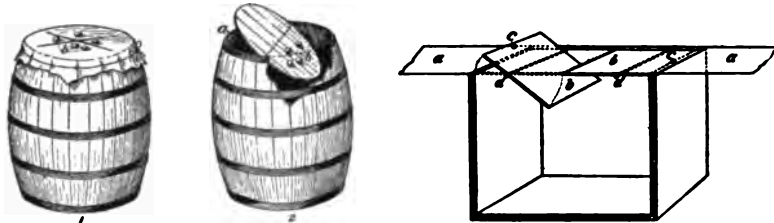

Trap illustrations by courtesy of U. S. Department of Agriculture.

TRAPS. The figure-four trap, as shown in Fig. 1, can be used with a packing box, as shown in the photograph on page 90, or it may be used with a weighted board as a dead fall. If a box is used, fasten on the lid with hinges at one end. This is necessary so that, when the box is lifted from the ground, the animal will not escape. If the trap is for rats or mice, the box selected should be small so that it can be put into an ordinary water bucket. To hold the trap in a set position it is necessary that the weight of the box rest on the top of the catch piece. A slight movement at the bait end of the trigger will cause the set pieces to fall apart and the box will drop with a bang. For the traps for the smaller animals the sticks to make up the Fig. 4 should not be as large as those suggested in the drawing because, if the sticks get caught between the edges of the box and the lid, there will be an opening left large enough for the rodent to escape.

The traps suggested in Figs. 2 and 3 are made by pivoting the lid so that a slight weight on one side will cause it to tip down quickly. The lid of the barrel should be battened and the edges trimmed off so that it will be small enough to work freely within the top of the barrel. The bait fastened to one side, as suggested, will tempt the rat or mouse, and their weight will make the lid tip, and cause the rodent to be dumped into the barrel. One side of the lid should be slightly heavier than the other, so that the lid will come back into position. This can be made by fastening a weight under one side, or by pivoting the lid very slightly out of center. A stop must be fastened on one side of the barrel for the lid to set even with the top of the barrel, and one on the side near the pivot to prevent the lid from swinging clear around.

TRAPS

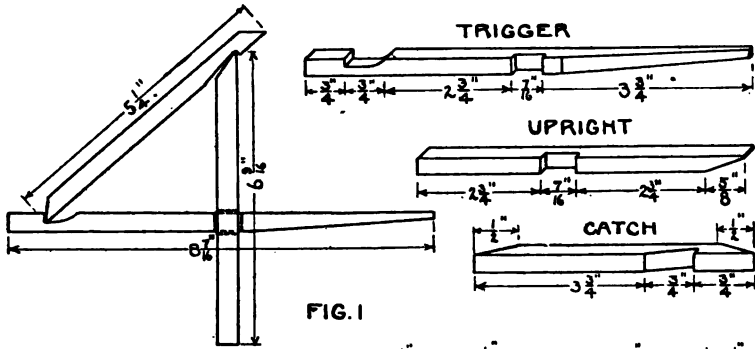

STOCK FOR FIGURE FOUR TRAP

- 1 TRIGGER $\frac{1}{2}$ " x $\frac{3}{8}$ " x $8\frac{1}{2}$ "
- 1 UPRIGHT $\frac{1}{2}$ " x $\frac{3}{8}$ " x $6\frac{1}{2}$ "
- 1 CATCH $\frac{1}{2}$ " x $\frac{3}{8}$ " x $5\frac{1}{4}$ "

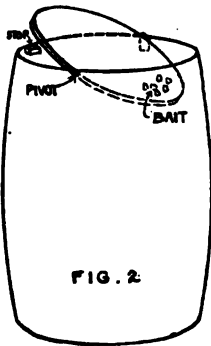

- STOCK
- 1 BARREL OR KEG
 - 1 BARREL TOP

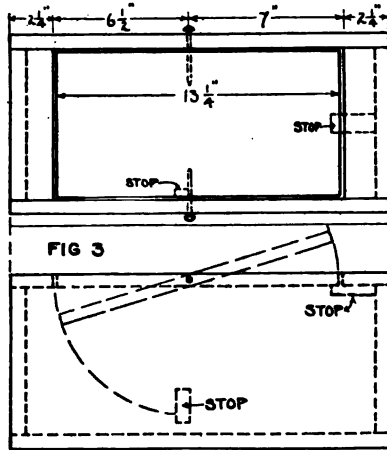

STOCK

- 2 SIDES $7\frac{3}{4}$ " x $\frac{3}{4}$ " x 18"
- 2 ENDS $7\frac{3}{4}$ " x $\frac{3}{4}$ " x $6\frac{1}{2}$ "
- 1 BOTTOM $7\frac{3}{4}$ " x $\frac{3}{4}$ " x 18"
- 2 TOP (ENDS) $2\frac{1}{4}$ " x $\frac{3}{4}$ " x $7\frac{3}{4}$ "
- 1 TOP (MIDDLE) $7\frac{5}{8}$ " x $\frac{3}{4}$ " x $13\frac{1}{2}$ "
- 2 STOPS $\frac{3}{4}$ " x $\frac{1}{2}$ " x 2"

The trap suggested in Fig. 3 is large enough to catch rats and small enough to fit into the ordinary water bucket. The cross-section view on the opposite page shows the same construction with a dropping lid on each side of the box. See also Box Traps on page 90.



BOATS. In making Fig. 1 first shape the bottom piece. Next nail the end pieces to the bottom before shaping their edges to match the curve of the sides. Note that the grain of the wood in the ends runs vertical. This is done so that when put in the water the bottom and end pieces will swell proportionately in width. In fastening on the sides begin at one end and tack to the edge of the bottom piece. Press the side in position and tack down tightly a little at a time until the side piece fits up against the edge of the bottom piece all the way along. Spring and nail the seat into place. This will help to keep the sides in shape. If it is difficult to bend the sides into shape, soak them in hot water or steam them, and they will be more pliable. A small hole can be bored through the middle of the seat and part way into the bottom; and a small rod put in on which may be fastened a flag or a paper sail.

In Fig. 2 cut out the back $\frac{1}{8}$ " or $\frac{1}{4}$ " wider than the paddle so that it will not strike the boat. One or two pieces can be used for the paddle wheels. If made of two pieces, the middle part must be cut for a cross-lap joint. To hold the paddle wheel in place on the boat, notches are cut to receive the rubber band. Put the rubber band in place, twist by turning the paddle wheel backward; and it is ready to run. The hub or center of the paddle wheel for Fig. 3 can be made of any circular or octagonal piece. A large spool will do. With a thin saw make the grooves for the sheet metal pieces. The metal must be thick enough to hold in tightly, but not too tight, else it will split. Staples

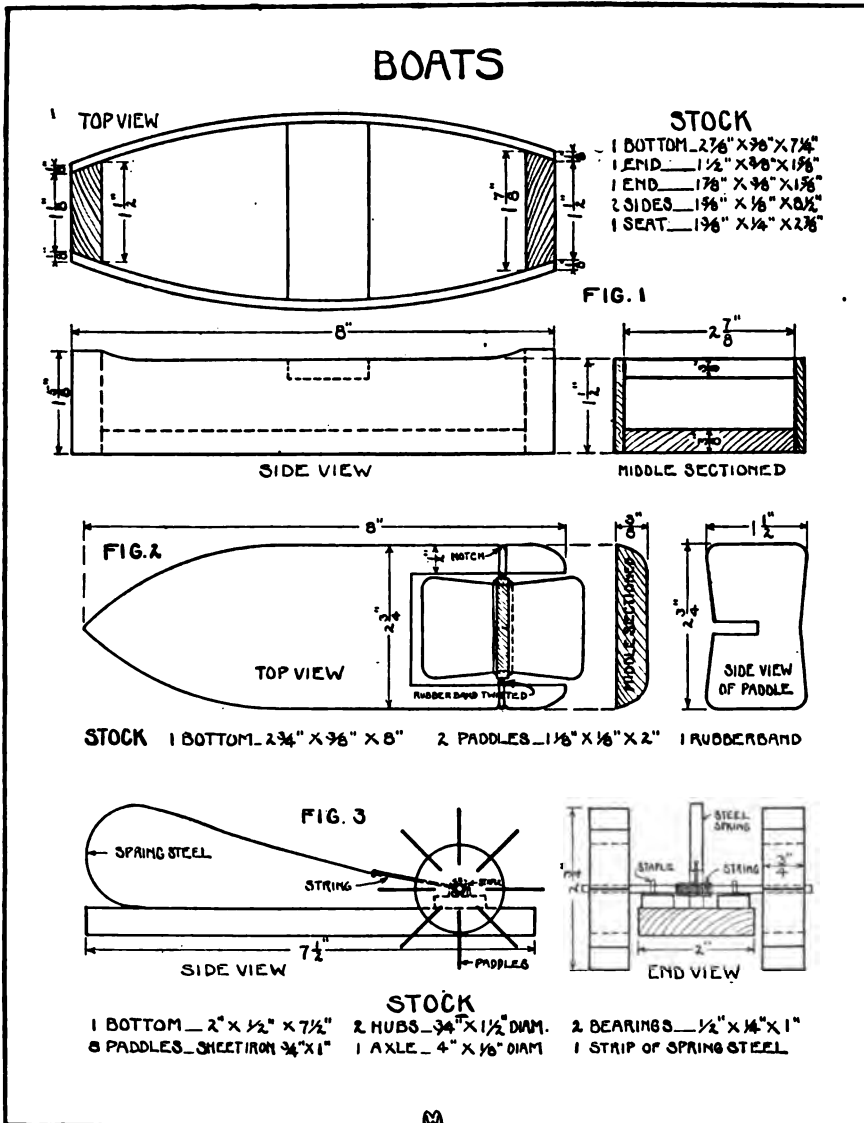

should be used to hold the axle in place. This can be made of a wooden dowel or a piece of wire. The hubs must be secured tightly to this axle. A steel spring from a corset will serve for the power. Fasten with a fine cord and wind up into the position as shown in Fig. 3.

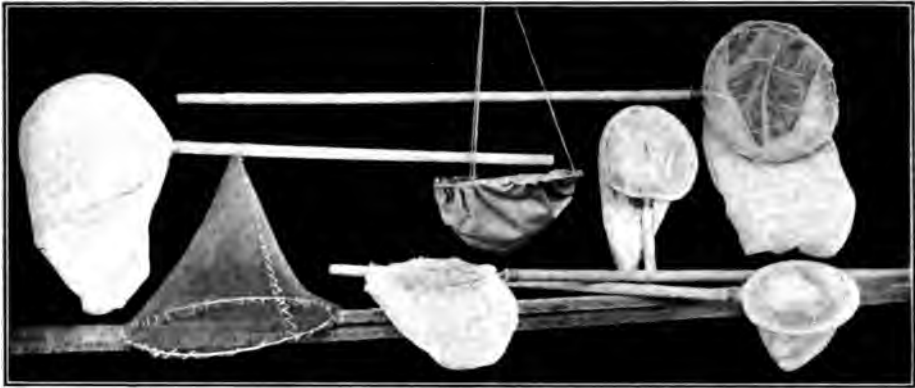

NETS AND INSECT BOTTLES. The net as suggested in Fig. 1 is used for catching all kinds of insects. Every boy and girl should have one of his own. By means of it a supply of nature-study material can be readily obtained. No. 12 spring brass or steel wire 4 or 5 feet long should be used for the ring. Put the wire around the end of any cylindrical surface about 10" or 12" in diameter, and give it one or two tight twists. A broom stick can be used for the handle, but it has been found to be somewhat heavy. A light wood should be used.

Several methods of fastening the ends of the wire to the handle are suggested in the drawing. Fig. 4 shows a hole slightly larger than the wire bored through the middle of the handle about 2" from the end. The loose ends of the wire should be about 3" long. Place the ends of the wire alongside of the handle, one on each side, and turn the points into the hole, previously bored, as shown in Fig. 4. To hold this securely in place, put it in the vise, squeeze it tightly enough to force the wires into the surface of the wood, and finally wrap with fine binding wire or cord, as shown in the drawing. The method shown in Fig. 5 is made by twisting the free ends of the wire throughout their entire length, which should be about 2" or 3". Then bore a hole in the center of the end of the handle, just small enough for the twisted ends of the wires to be forced in. In Fig. 6 two holes slightly smaller than the diameter of the wire are bored into the end of the handle. Into these holes the ends of the wire are forced. This

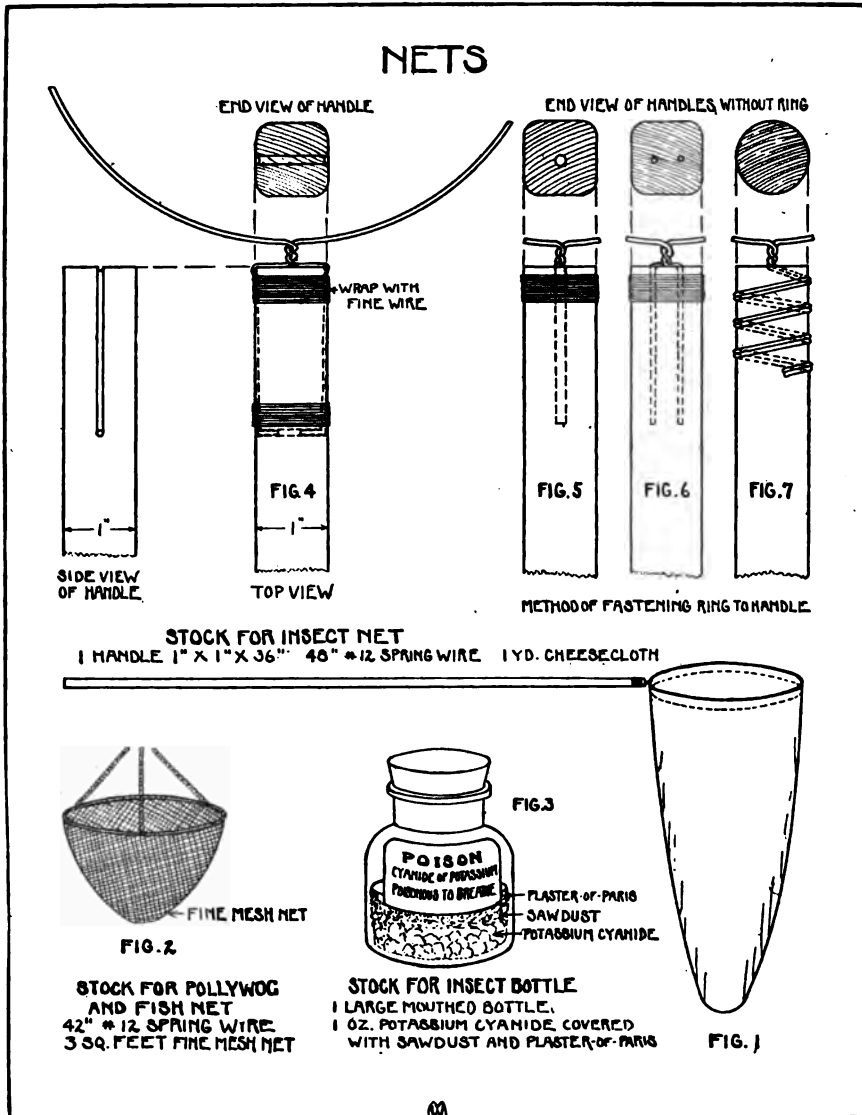

and the one previously suggested should be wrapped very firmly with binding wire so as to hold the ends of the wire more firmly in place and to prevent the handle from splitting. Sometimes these types are made so that the handle can be slipped on and off as desired. Fig. 7

allows for this very readily. The ends of the wires are wrapped very tightly around a round stick in the form of a spiral. This cuts a thread or a spiral depression so that the handle can be screwed on and off as desired.

Mosquito netting can be used for the net, but cotton tulle or cheesecloth lasts much longer. A narrow strip of heavier cloth such as muslin should be sewed around the wire ring and the lighter cloth sewed to this. Dr. Hodge suggests that the depth of the bag be a little more than twice the diameter of the ring, so as to lap over and close well when an insect is caught.

The insect bottle (Fig. 3) has been suggested by Dr. Hodge. He says: "To preserve your insect, you must first kill it without injury and this is best done with a cyanide bottle. Get a wide mouthed bottle and a good cork to fit it tightly. In the bottom put an ounce of potassium cyanide broken into lumps not larger than a filbert; add sawdust a little more than enough to cover the largest lumps and pour in plaster of Paris, mixed to a consistency of thick cream, to form a layer a quarter of an inch thick. The plaster will harden in a few minutes, and an insect dropped in and corked up will die almost instantly and without injury or apparent suffering. What kills the insect is the fumes of the cyanide coming through the plaster and saturating the air within the bottle; hence, avoid breathing any of these fumes yourself and keep the bottle tightly corked at all times. The cyanide is a deadly poison, and the fact that it is a harmless-looking white substance, not unlike lump sugar or rock salt and many other things, renders it one of the most dangerous poisons to keep about the house. (Label the bottle as in Fig. 3.) Such a bottle will remain good for a season. If moisture collects in it, wipe dry with blotting paper or a soft cloth.

"Insects may be killed with chloroform. If this is preferred, get an ounce of it in a flat vial; stick the handle of a camel's hair brush into the bottom of the cork; and, holding the insect in a fold of the net, apply a drop of chloroform to each side (for insects breathe through a row of minute holes along the sides), and the insect dies instantly.

“On a collecting trip you will also need a newspaper, in which the insects may neatly be folded without breaking the wings or legs.”¹

A word of caution as to the purpose of catching insects will not be out of place here. The collecting should not be the aimless catching of any flying thing that happens to attract the attention, but the aim should be to learn to know the important things about the most important insects, to know about those which are destructive and those which are beneficial. Dr. C. F. Hodge, in the chapter Plan for Insect Study, of his book *Nature Study and Life*, suggests: that we collect insects and study them so as to be able through favorable conditions to propagate and make use of the insects that are beneficial to combat and destroy those that are injurious.

On account of the peculiar development of insect life it is necessary to understand the life story of the insect, which means all the changes it goes through from the time it hatches from the egg to the time it dies. Most insect eggs like the caterpillar hatch out quite differently from the parent and then go through several stages of development before the adult insect appears. With the destructive insects it is very necessary to know the whole life story so as to find their weakest point, that we may most easily destroy them. With the beneficial insects this knowledge is necessary so that we may develop and propagate them.

A fine mesh fish net is most suitable for the minnow and polliwog net shown in Fig. 2. This can be purchased at any sporting goods house. The net should be slightly less in depth than the diameter of the net so that it can readily be inverted over the bucket to receive them.

A ring of wire must be made on which to fasten the net. It can be fastened to a ring with a handle, as previously described for the insect net, but it is more convenient to have it fastened by a cord, as shown in Fig. 2. By a cord, the net can be lowered into the water and quickly and quietly lifted up, whereas the wooden handle of the net is liable to frighten away the fish and polliwogs.

¹ Hodge, *Nature-Study and Life*, pp. 51-52.



WINDMILLS AND VANES. Windmills admit of a great variety of possibilities in construction and in the use of materials. The construction and material must be such that they will not be affected by sun or rain. The propeller (Fig. 1) involves modeling with the knife and a cross-lap joint. The shaft can be planed up octagonal or round, as described in Figs. 4, 5 and 6 on page 61, and the vane can be cut out with the coping saw.

A one-piece propeller with but two projecting blades or wings can be used as seen in the photograph. This would be the same as Fig. 2 without the middle groove cut out. If two pieces such as Fig. 2 are made and put together a cross-lap joint construction such as is shown in Fig. 1 will be the result. The blades should be marked out but not whittled until the cross-lap joint is made and the glue dry. Propellers with as many as six or eight blades can be made, but the cross-lap joints required for such ones are very difficult to make.

The hub propellers are very much easier to make than those just described. They can be made with any number of wings. Figure 5 is a four-winged propeller. After cutting out the block for the hub, saw grooves obliquely into each edge at least $\frac{1}{4}$ " in depth and just wide enough for the wings to fit. Fig. 6 is a drawing of the wing blade, and Fig. 7 is a drawing of the hub. Care must be taken that the wings are not forced in, else the hub will split. If six or eight wings are desired, make a hexagonal or octagonal hub and saw grooves. The grooves should have the same slant on all sides.

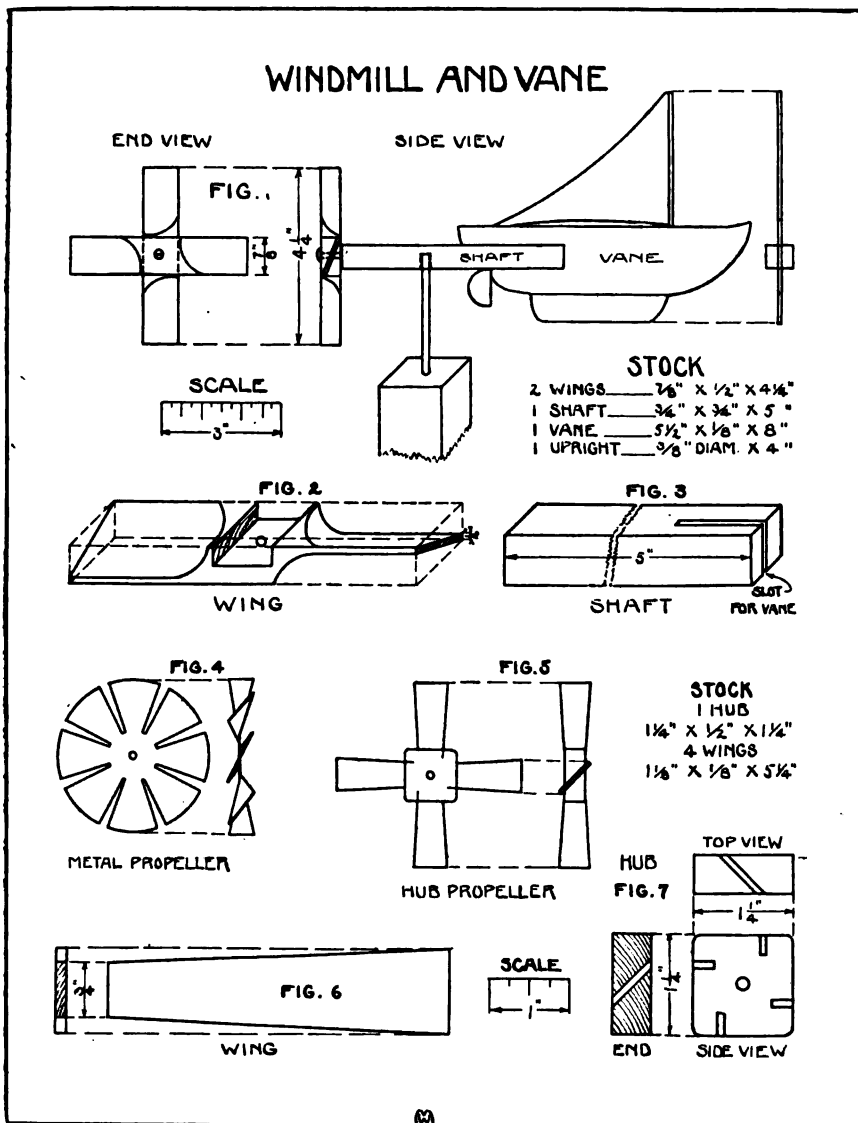

A metal propeller can be made very much more readily than one of wood. The metal must be fairly stiff so as to hold itself in shape. Sheet iron about No. 22 gage "American Standard" is very desirable. The simplest two-blade propeller can be made of a narrow strip of

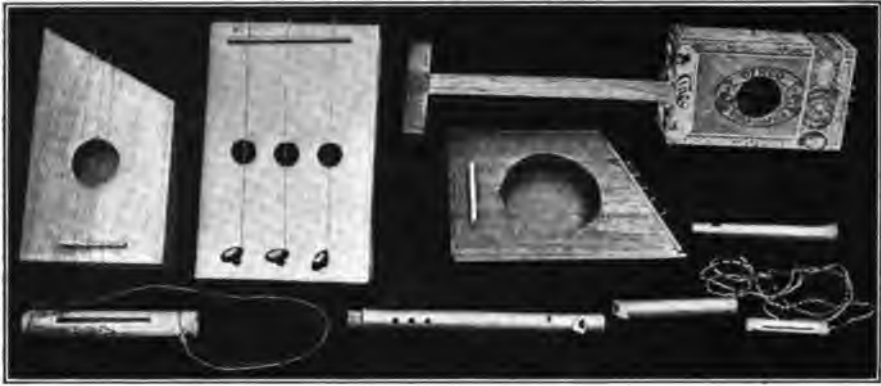

STRING AND WHISTLING INSTRUMENTS. All of the problems shown in the photograph were made by young children in taking up the study of sound. The zither, suggested by Fig. 1 of the drawing, is made to obtain varying tones. Seven tones were produced by means of seven lengths of wire, cord, or cat-gut strings. Any number of tones can be produced by using various lengths.

Another method of getting various tones is by having the strings the same length and varying the thickness of the strings. In this case the box can be made rectangular. Silk thread can be used. The varying thickness of strings can be obtained by taking the desired number of threads, and twisting them together.

To make the instrument suggested by Fig. 1, first make the box, fastening it together with glue and very thin brads. Extreme care must be used in putting the brads in this thin wood, because the wood is liable to split. It is well to fasten the bridge and the corner piece to the top before putting the top on the box. When two or three lengths of strings only are used, a large round hole or several small holes, one for each wire, can be used. This is shown in the photograph. If several strings are used, it is best to cut the hole oval in shape, as suggested in Fig. 1. It is well to make the bridge of hard wood. If more resonance is desired, a steel wire such as a hat pin can be embedded in the top edge of the bridge. This is shown in the drawing. The tuning pegs, used to keep the strings taut, can be made; but it is more convenient to buy them at a music store, where

STRING AND WHISTLING INSTRUMENTS

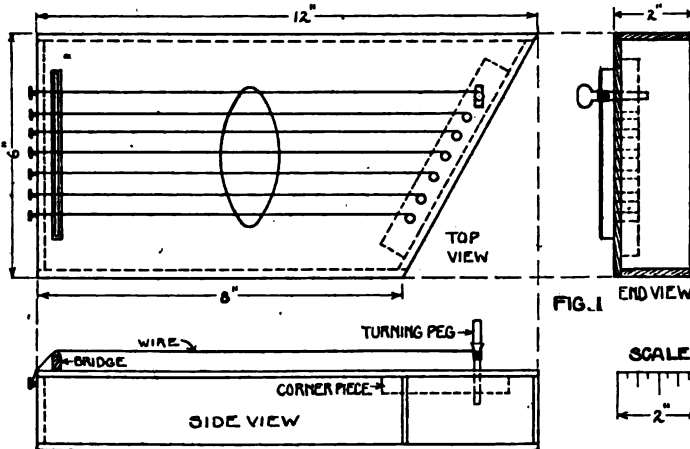
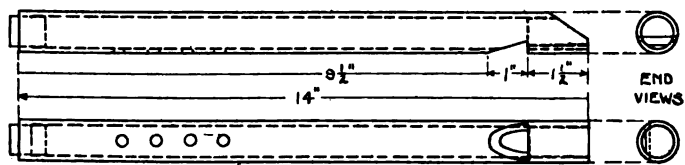

FIG. 1 END VIEW



- | | | |
|------------------------------|----------------------------|-------------------------------------|
| STOCK | | |
| 2 TOPS_6" X 1/8" X 12" | 1 BRIDGE_3/8" X 3/8" X 4" | |
| 1 END_1 3/4" X 3/4" X 5 7/8" | 1 SIDE_1 3/4" X 3/4" X 12" | 1 CORNER PIECE_3/4" X 3/8" X 5 1/2" |
| 1 END_1 3/4" X 3/4" X 6 1/8" | 1 SIDE_1 3/8" X 3/4" X 8" | 7 TURNING PEGS AND WIRES |



STOCK 1 BAMBOO ABOUT 14" LONG - 2 CORKS FIG. 2

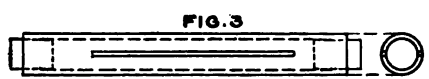

FIG. 3 STOCK 1 BAMBOO ABOUT 6" LONG

they can be obtained at little cost. If the pegs are made by hand, be careful that a long taper is made, otherwise the sudden or short taper will not hold in firmly and is liable to split the thin wood.

To string the instrument, first fasten the ends of the strings to

brads located at one end of the box. The other ends of strings are passed through the holes in the tuning pegs. The pegs are then put in position and wound up until the strings are taut. The drawing shows one of the pegs only in position. The peg is tapered so that when pushed in firmly, it will not slip around and slacken the string. The corner piece is put in to strengthen the wood so that, when the pegs are forced in, they will not split the top piece.

A much simpler, but less effective, apparatus can be made by using a solid block of wood instead of the box; and nails instead of the tuning pegs, the wire being pulled taut and then tied securely to the nail.

A banjo effect can be produced by attaching a handle to a cigar box, as shown in the photograph. The end of the handle is fastened to the inside of the cigar box lid, and the end of the box cut away so as to allow the lid to shut down tightly.

Fig. 2 is the drawing of what the boys please to call a "Fife." The one shown in the photograph is made of one length of bamboo. One end is plugged up tightly with a cork to form the air pocket. If the bamboo is cut so that the joint comes at this point, the cork is not needed. The opposite end must have a plug of cork or wood fitted in it. Before fastening this plug in place, cut one side of the plug flat, as shown by the end views of Fig. 2. This plug is fastened in $1\frac{1}{2}$ " or less from the end. Next cut a notch in the bamboo on the same side as the flattened part of the plug. Also bevel the back off, as shown in the drawing. As the cutting proceeds, test by blowing. Stop cutting when the desired tone is obtained. By varying the size of the opening, the notch, and the chamber, different tones will result. The small holes shown in the top near one end are intended for the fingers.

The ordinary whistle is made in the same way, as already suggested by Fig. 2, except that the chamber is made very much shorter. If bamboo is not available, a piece of soft wood with a hole bored in it can be used, or a piece of willow with good strong bark on it may be used. If a pea or other round substance is put in the chamber before fastening in the plug, a peculiar vibrating tone is obtained.

A "humming bird" is suggested by Fig. 3. A piece of bamboo is cut off at the joints, or the ends are plugged up with corks. Long,

narrow slits are cut in two sides, and a string is fastened to one end, as can be seen in the photograph. When this is swung around in the air rapidly, a peculiar whistle or humming sound is produced. The tone will vary according to the size of the chamber and the open slits.

From such crude beginnings boys and girls have been led to make instruments of value. For high school students ukuleles, zithers, and banjos can be worked out, as shown in the illustration below.

The best plan is to obtain an instrument of simple strong construction and use it as a model to pattern after. Thin mahogany veneer for the box part or other hard resonant wood can be obtained from the mill. The piece for the sides is thoroughly steamed or soaked in hot water and then clamped into the curved shape between two pieces of wood, one the exact shape of the inside of the box part and the other the outside shape of the box. This outer piece must, of course, be in two parts split down the center. After the wood is thoroughly dry, the clamps can be removed and the piece will retain the shape into which it has been pressed.

Pieces about $\frac{1}{4}$ " \times $\frac{1}{2}$ " must be glued securely to the top and bottom all round the inside corners so as to keep it from warping. Fasten securely the top and bottom to the sides. Nails must not be used. The opening must be cut, and the corner pieces and bridge must be fastened in place before putting together.

An ingenious instrument is made thus: Fasten a fine wire or guitar string lengthwise to a board. Put a strip of wood at each end to elevate the wire about $\frac{1}{4}$ ". Stretch it taut with a tuning peg. To play on it, take a cigar box with lid or one end removed. Rub the open edge of the box on the string. Rosin will help. With a little practice interesting and amusing effects can be produced.



Ukulele made by High School Student

SWINGS. For the construction of swings hard wood is preferable. The child's swing, Fig. 1, is for young children. If less work is desired all the strips can be made straight instead of curved.



The holes in all the pieces should be slightly larger than the diameter of the rope used. With $\frac{3}{8}$ " rope the holes should be $\frac{1}{2}$ " in diameter. Notice that the holes in all of the pieces (Figs. 2, 3, 4 and 5) are $\frac{3}{4}$ " from the ends, while from the sides they are but $\frac{1}{2}$ ". This is done to obtain equal strength all around, the short grain at the ends being weaker than the grain at the sides. The work should first be laid off and the holes bored (fasten in the vise while boring the holes to prevent splitting) before cutting to the outline. After the bottom or seat piece is laid off, test to see if it is square by measuring from corner to corner. The length of the two diagonals should be exactly the same. Next, lay back, front, and side strips on the seat piece to see if the holes and outlines match up. The holes can be bored and the outline drawn with these pieces thus in place. The uprights are made from a piece of bamboo. If this bamboo is not at hand, use cotton spools; or use straight grained soft wood.

Select a piece about 1" square, saw four pieces off the proper length, bore a $\frac{1}{2}$ " hole through them lengthwise, and then round them up.

When setting up the swing, the rope should be knotted as shown in Fig. 1, or slipped all the way across as in Fig. 7. When knotted it will always remain level if properly set.

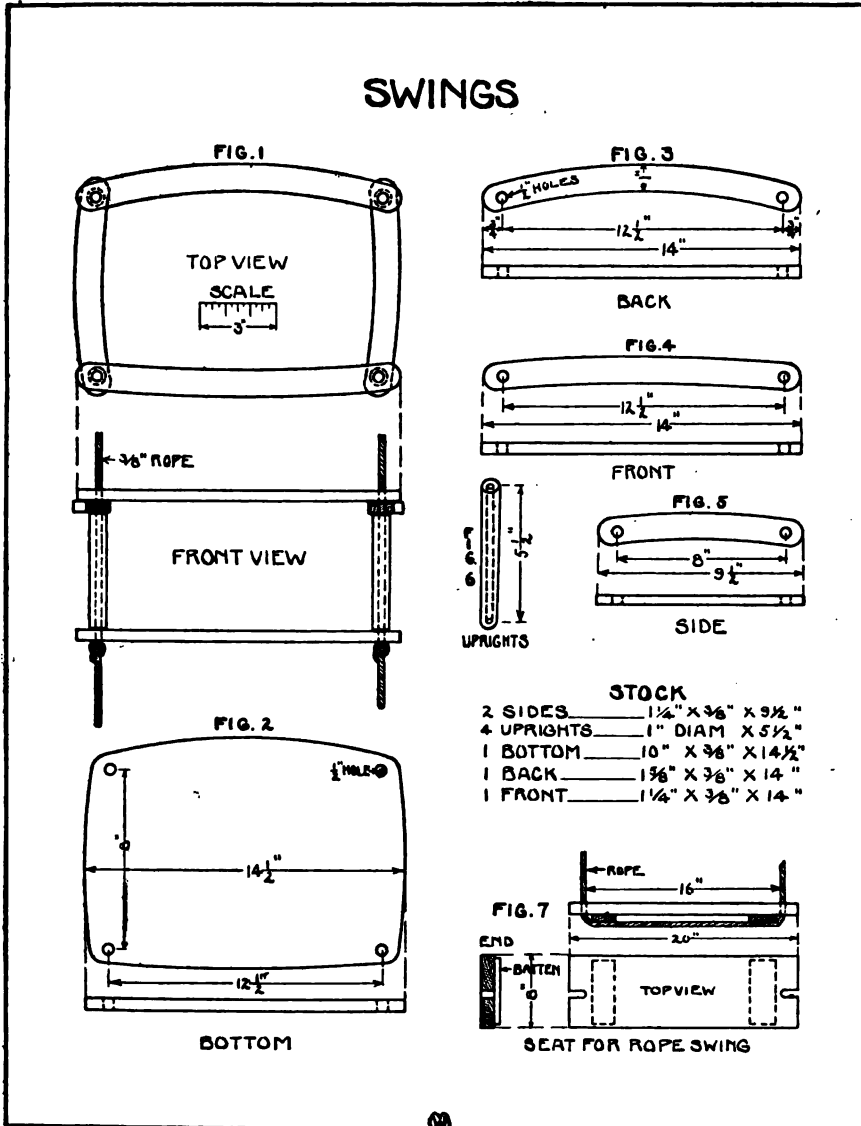

Fig. 7 is a seat for the ordinary rope swing. Batten pieces should be fastened underneath across each end. The sharp corners of the wood should be rounded off wherever the rope touches it, to prevent cutting the rope.



MAP AND POST CARD PICTURE PUZZLES. The educational advantage of this puzzle lies in its possible correlation with geography and history. The sawed lines can be the boundary lines of states and counties or townships, or the pieces can be sawed so that one or more cities may be located on each piece.

Before making the frame, paste or glue the picture securely to a thin board not more than $\frac{1}{4}$ " in thickness. While drying press it flat.

The frame to hold a post card $3\frac{1}{2}$ " \times $5\frac{1}{2}$ " is shown in Fig. 1. The bottom of the frame should be about $\frac{1}{2}$ " larger all around than the card; for instance, the bottom piece of Fig. 2 must be $4\frac{1}{2}$ " \times $6\frac{1}{2}$ ", thus allowing $\frac{1}{2}$ " for width of rim all the way around the frame. After making the bottom piece, cut out the strips for the rim, which should be the same thickness as the piece upon which the card is mounted.

To assemble the parts, first glue and nail one side and one end strip to the bottom piece; then slip the card into place; and next nail the other side and end strips on the bottom piece. Use nails long enough so that they can be clinched. With the larger frames battens are necessary to keep the bottom piece from warping.

Unless the state or county boundaries are to be followed, care should be used so as to avoid short grain, so that the projections cannot easily be broken off. For directions in the use of the coping saw see page xxiv.

The post card box (Fig. 2) is the type of box construction in which the butt joint is used. In a box construction the sides of the box should always be the entire outside height and the entire outside

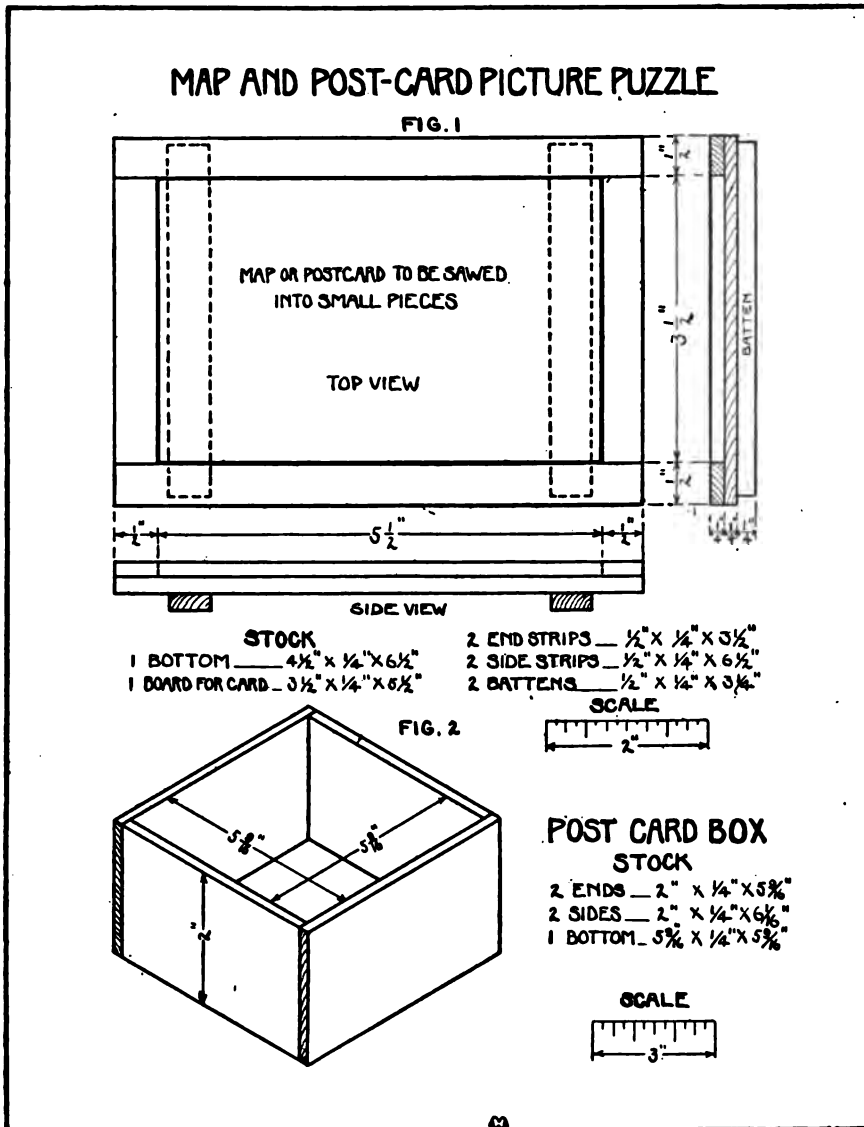

length; the bottom piece should be the inside width and the inside length; and the ends should be the entire outside height and the inside length of the box. The bottom always fits inside, and the end pieces fit in between the side pieces.



PRINT FRAMES. Printing frames can serve a variety of purposes, especially in connection with shop work, nature-study work, and photography. The frame shown in the photograph contains prints of leaves used in making a collection of leaf prints. The frames in Figs. 1 and 3 are designed for 5" × 7" print paper. The inside of the frame should be at least $\frac{1}{8}$ " larger each way than the paper to be used. If larger frames are made, the material should be proportionately heavier, and the back should be made of two pieces hinged in the middle with a batten fastened to each piece. The middle frame in the photograph shows the back in position with the rubber band holding it in place. If desired a piece of spring steel in place of the rubber band can be used for the larger frames. Fasten the strip of steel to the top edge of the batten, and adjust so that the ends will slip under the head of round-headed screws or slits made in the edge of the frame.

The simplest construction for the frame is made by simply nailing the several pieces together as shown in the center of the above photograph and in Fig. 1. If nails which are slightly longer than the thickness of the frame are used, the ends can be turned and clinched. This fastens the two strips securely together.

If advanced technique is desired, any one of a number of joints can be used in putting the frames together. The simplest joint is the end lap joint as shown in Fig. 3. Glue and screws, or nails clinched, should be used to secure a strong joint. With the large frames a piece

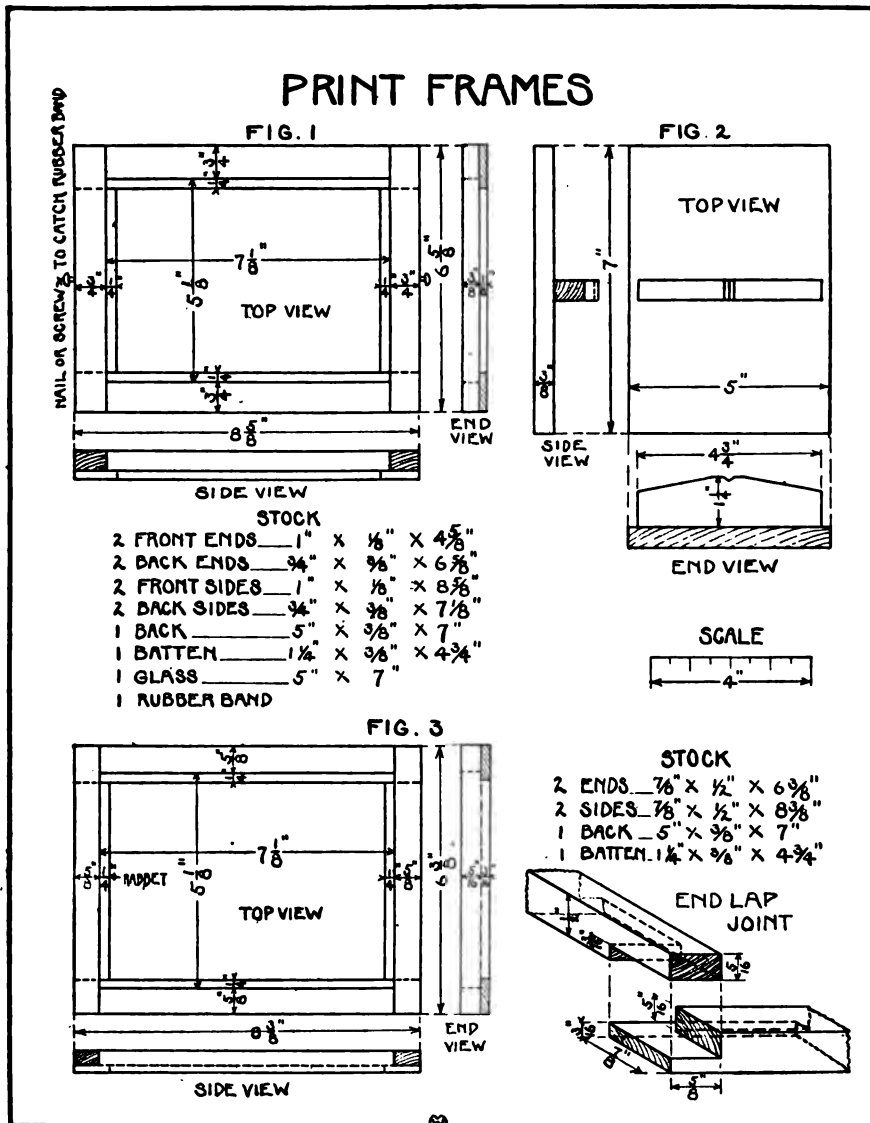

of felt is usually used. This is placed next to the paper so as to hold the paper firmly against the tracing or negative. The felt is somewhat expensive. If it cannot be used a piece of cardboard or heavy cloth or paper will take its place very satisfactorily.

SCISSORS AND DANCING JACKS. The scissors jack (Fig. 1) is put together by first marking the position of the nail holes and starting the nails; and then by laying all the pieces down in position, and driving in the nails. Be sure the ends line up evenly as shown in

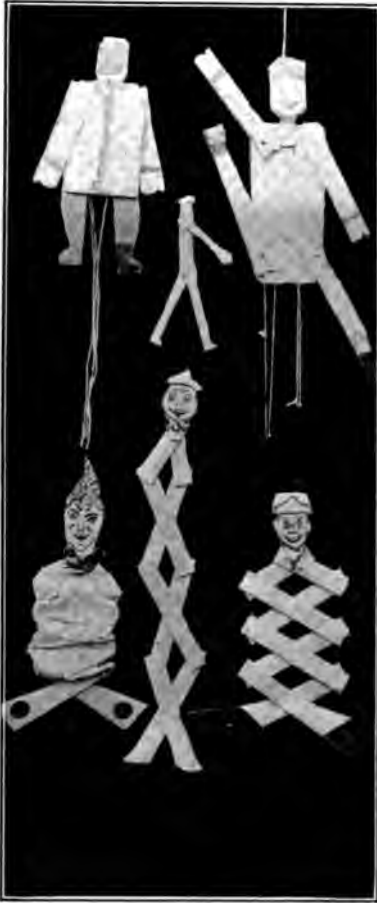

the drawing. The nails should be $\frac{3}{4}$ " long, that is, long enough for the point to go through and to be turned over and clinched. Care must be taken in driving the nails in lest they split the wood at the ends. Reject all pieces that start to split. If considerable care is used holes can be bored in the foot pieces without splitting. These holes can be used in which to insert the thumb and finger. Any even number of body pieces can be used. The ones in the photograph show four only, while six are shown in the drawing. If desired the jacks can be clothed with a flowing robe, and a facial expression can be painted as suggested in the photograph.

The string jack (Fig. 3) shows a very simple modification of outline. The shape of the parts of the body are produced by a few notches. Fig. 3 shows a view with the front body piece removed so as to make the arrangement of the parts clear.

The position of the arms and legs shows the strings pulled down until the arms and legs are in a horizontal position. The strings can be fastened to the ends of the arms and legs through holes as suggested, or to nails fastened in the ends of the pieces. Follow the directions for fastening as suggested in Fig. 1.

JACKS

FIG. 1

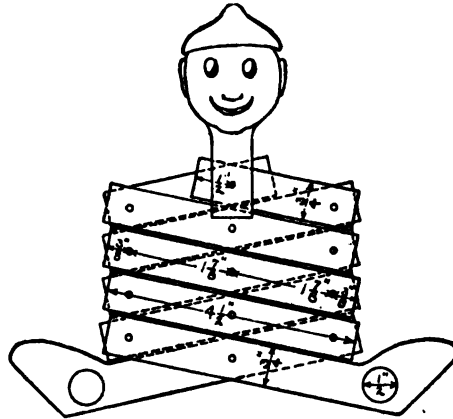

SCISSORS JACK

- STOCK
- 2 SHOULDERS $\frac{3}{4}$ " x $\frac{1}{8}$ " x $2\frac{3}{4}$ "
 - 1 HEAD 2 " x $\frac{1}{8}$ " x $4\frac{1}{2}$ "
 - 6 BODY $\frac{3}{4}$ " x $\frac{1}{4}$ " x $4\frac{1}{2}$ "
 - 2 LEGS $1\frac{1}{2}$ " x $\frac{1}{4}$ " x $6\frac{1}{2}$ "

SCALE

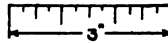
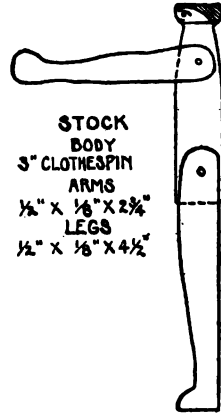

FIG. 2



CLOTHESPIN JACK

STRING JACK

- STOCK
- 1 HEAD $1\frac{3}{4}$ " x $\frac{1}{2}$ " x $6\frac{1}{2}$ "
 - 2 ARMS $\frac{3}{4}$ " x $\frac{3}{16}$ " x $4\frac{1}{8}$ "
 - 2 LEGS 1 " x $\frac{3}{16}$ " x $5\frac{1}{2}$ "
 - 2 BODY 3 " x $\frac{3}{16}$ " x $4\frac{1}{2}$ "

FIG. 3

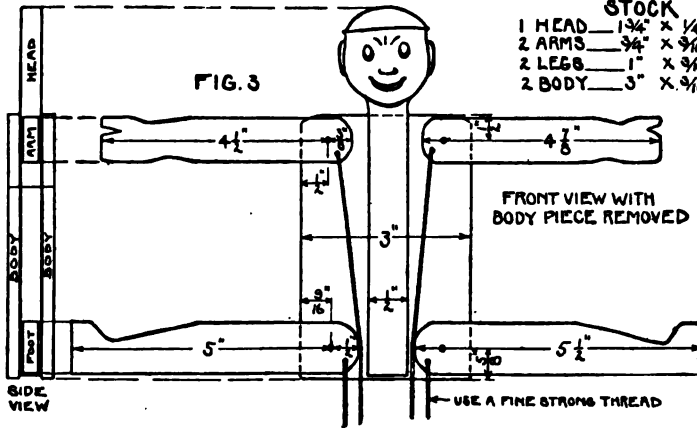

If desired the jack can be dressed and facial expressions added. The clothespin jack (Fig. 2) is a clothespin cut off at the end and arm and legs added. If the nails are put in so that the legs do not swing too freely, a number of postures can be secured.



CLIMBING AND JUMPING JACKS. The climbing jack as shown in the drawing is made by fastening the arm to the body in a position slightly above the horizontal. The cardboard in the palm of the hand should not be fastened down too tightly. The string should slip between the cardboard and the wood with a little friction. The staple or double pointed tacks should be small. The one in the hand should be driven in lengthwise with the arm while the two in the leg should run crosswise. The leg should swing freely. When the string is loose, the rubber band should pull the leg up about as shown in Fig. 1. When the string is pulled taut as shown in Fig. 2, the position of the two staples in the leg holds the string at this point; while the string at the top easily slips down through the cardboard and the wood of the hand, or as it appears the hand slips up the string. This position is shown in Fig. 2. When the string is slackened and the rubber band pulls the leg up, the friction of the cardboard against the wood of the hand should hold the string tight while the changed position of the staples in the leg allows the string to slip up freely from below. If upon relaxing the string, it should slip through the hand, the cardboard should be fastened to the wood a little more firmly. If the rubber band will not allow the leg to straighten down enough, get a longer band or move down the nail which holds it on the body. This jack should climb about 5" with each pull of the string.

The jumping jack (Fig. 3) is made by taking a block of wood for the body and head, and having the arms and legs pivot freely. Strings

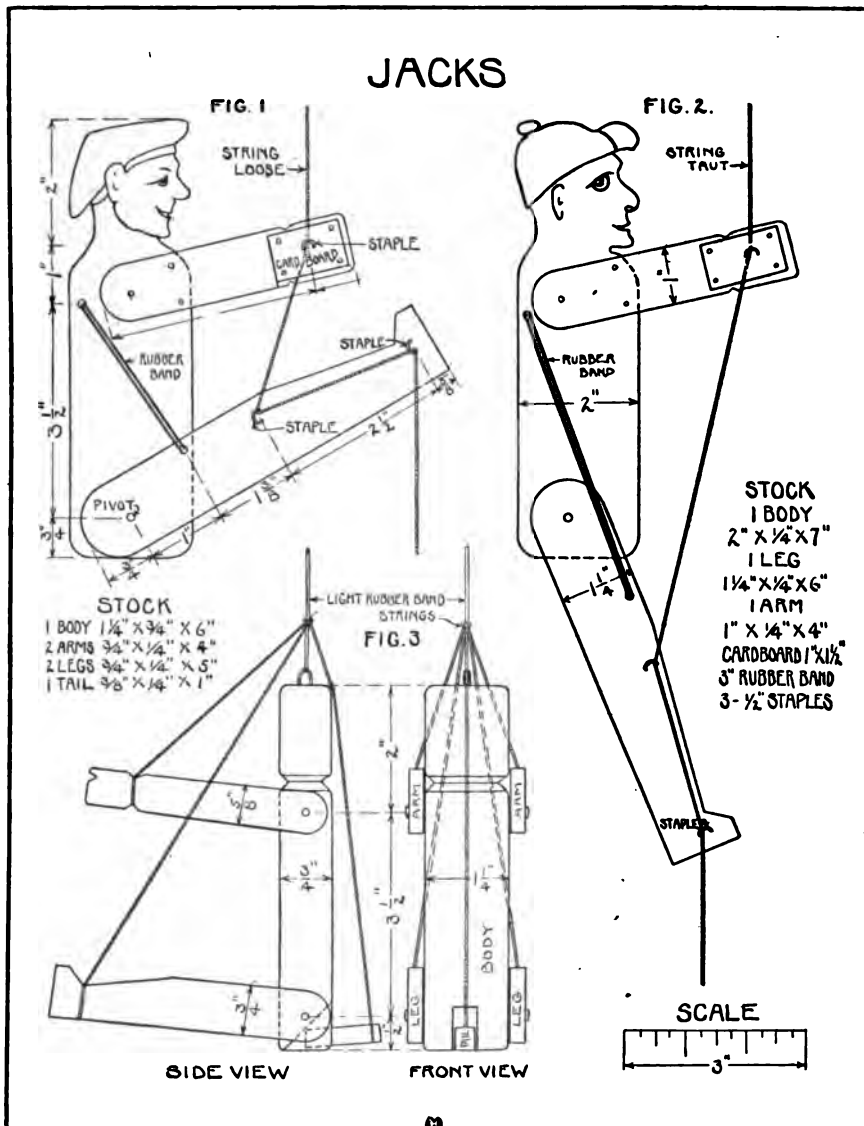

fastened to the extremities of the parts are brought together and fastened a short distance above the head to a light rubber band which is suspended from a nail at the top of the head. Jerking the end of the rubber band causes the projecting parts to move up and down.

GYMNASTIC AND POLE JACK. The pole jack (Fig. 1) is a simple construction. The action is shown in the photograph, the lower one with the handle down and the upper one with the handle up. The top part of the pole should be slightly thinner than the handle or bottom part.



The gymnast jack (Fig. 2) is also of simple construction in which all the joints must work freely. If more advanced technique is desired, the body may be made of a heavier piece. The one shown in the photograph is made of a piece $\frac{3}{4}$ " square. The joints may be similar in construction to that of the dolls on page 139. The uprights can be nailed to the crosspiece, but the continual strain on the uprights soon pulls the nails loose. A slim wire finishing nail or brad running through the several pieces, as shown in Fig. 2, should be used. The top part should be threaded with a piece of strong cord or thread as shown in Fig. 2. By pushing the handles of the upright in and out, vibrations are produced upon the string. This causes the figure to swing back and forth and over the cord.

A dancing or clogging jack can be made with parts of a broomstick for the body, a spool for the head, and bamboo or a small rod for the legs and arms. The ends of a spool can be shaped up for the feet. This jack must be made up with as many joints as possible. Bore a hole through the body; then fasten a string to the top of the feet and up through the legs, body, and out at the head. If it is not convenient

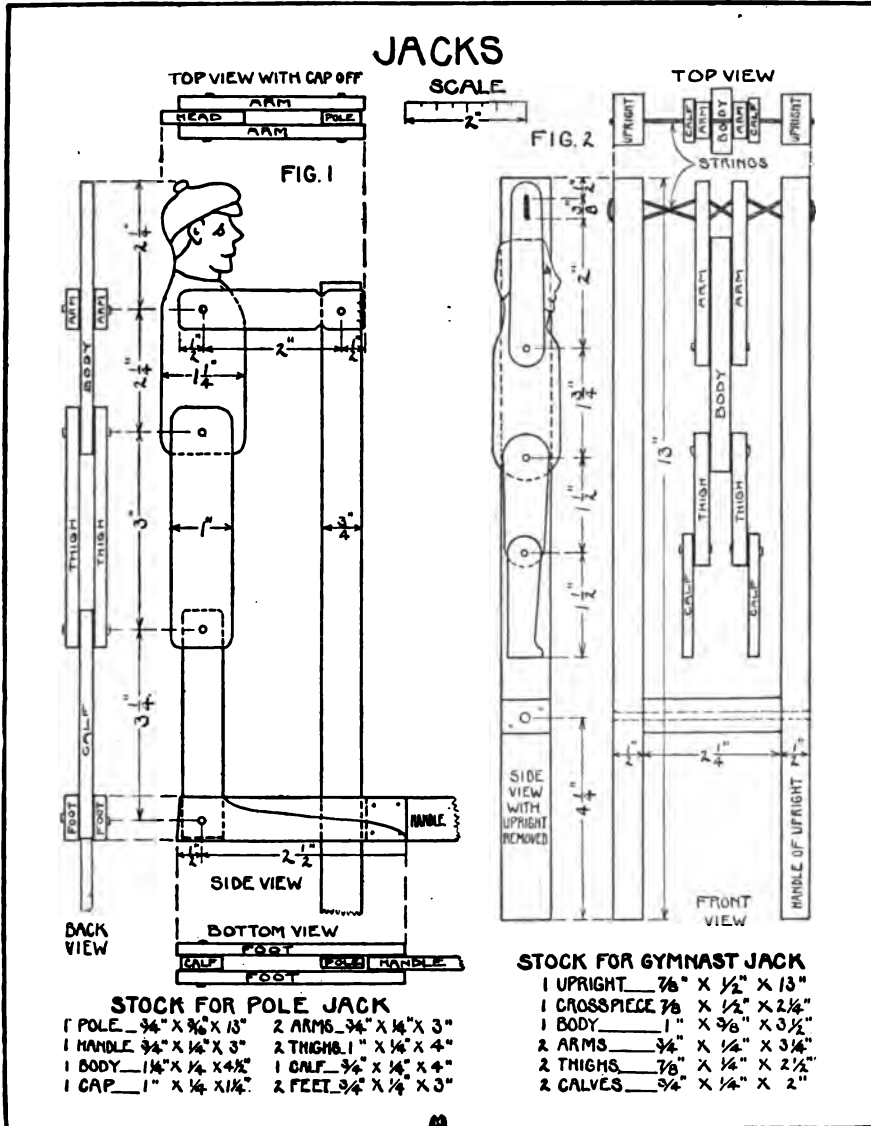

to bore the holes, tie the joints together with string. To work the jack suspend so that the feet will rest lightly on a thin board such as a shingle projecting over the edge of a table which when tapped lightly will vibrate and cause the jack to clog in great style.

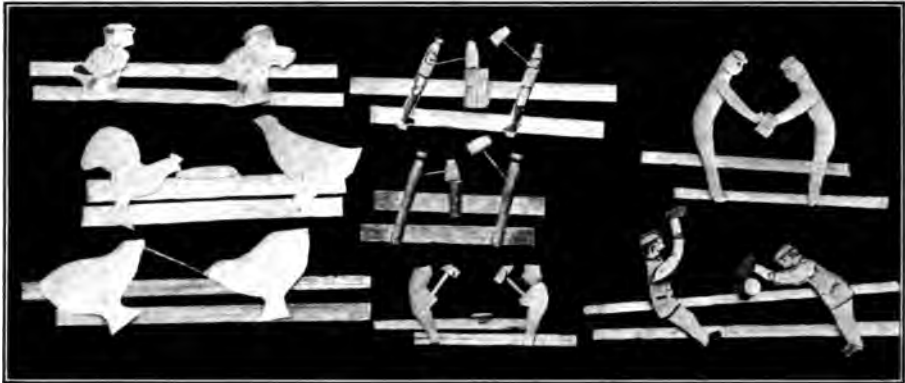

LEVER MOVEMENTS. The lever movement in a variety of forms is suggested in the drawing and the photograph. In Fig. 1 of the drawing is shown the "blacksmith clothespin boys." The anvil is made by sawing off the top of one clothespin. The arm can be made of a brad, a piece of wire, a match, or a small dowel. The proper fastening of the arm is difficult. Secure the arm to the hammer before sawing away the clothespin, as it is easier to handle and is less liable to split. The arm piece should be fastened to the hammer straight in, at right angles. The arm is fastened into the body slanting upwards. The parallel strips should not fit too tightly in the slots of the clothespin, else they will not work back and forth easily.

In assembling the parts, first nail the anvil securely to the center of one of the strips. Next, adjust the "boys" and fasten them, one on each side of this strip with nails to make the pivots so that the hammer will strike the anvil directly on top. With the clothespins in an upright position and the parallels at right angles to them the desired distance apart, drive in the two lower pivot nails, which should be long enough to allow the points to be bent over.

The heavy lines in the drawing show the position of the parts as they should be when fastening in the nails. The dotted lines show the position when the lower strip is shifted over, the right "boy" with hammer down on the anvil, and the left "boy" with hammer up-raised. Should the hammers be out of line adjust by bending the arm, if the arms are made of wire; but if of wood this is hardly possible.

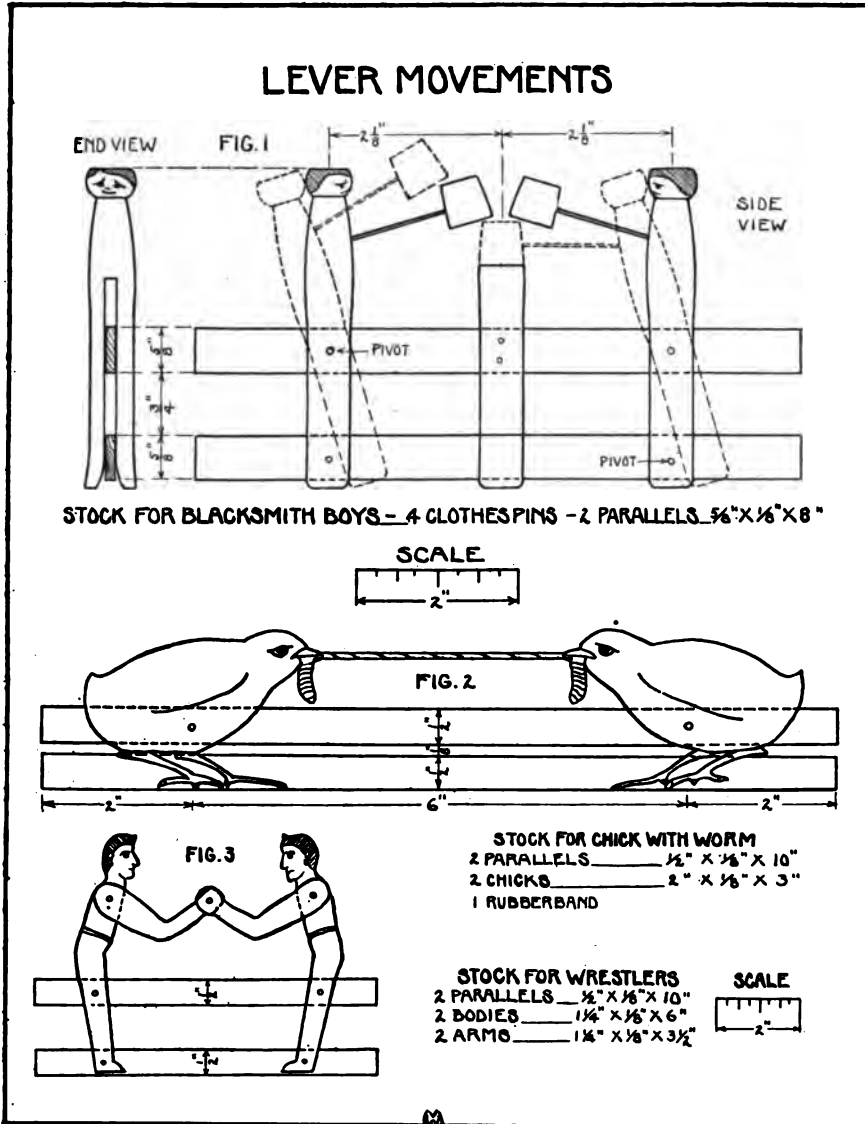

The "chicks with worm" and the "wrestlers" (Figs. 2 and 3) operate similarly to the "blacksmith boys," but are not as difficult to assemble. When driving the pivot nails in, the strips should always be parallel and the upright pieces should be in an upright position.



KNIVES AND DAGGERS. Knives can be made in a number of ways, depending on the use to which they are put. When carefully planned, they are excellent manual training problems.

The knife as suggested in Fig. 1 is made of two pieces, the handle and blade being separate. In one end of the handle, a slot is cut to admit the blade. Before gluing this firmly in position, the handle and blade should be modeled to the desired shape. Lines for the outline of the curves should be drawn, and these should be followed carefully if a good shape is to be expected. The knife suggested in Fig. 1 can be used as a dagger. If a hilt is desired it should be cut out of sheet metal or thin wood and fastened on as suggested for the construction of the fencing rods shown on page 63.

Figs. 2 and 3 serve excellently as paper cutters or envelope openers. Fig. 3 suggests chamfer modeling and Fig. 2 suggests round modeling. To get a good round shape, the wood should be worked to an octagonal or eight-sided figure as suggested on page 61.

Fig. 4 represents a dagger. A case can be made of cloth or leather. The handles and blades painted in contrasting colors, bronze for the handle and silver for the blades, is very effective.

Knives for paper cutting and letter opening can be made from sheet brass or copper. A pleasing pattern for the outline should first be cut out of paper and traced on the metal with a sharp pointed instrument. If the metal is thin the outline can be cut with tinner's shears, and if thick with a metal saw. When purchased the metal is

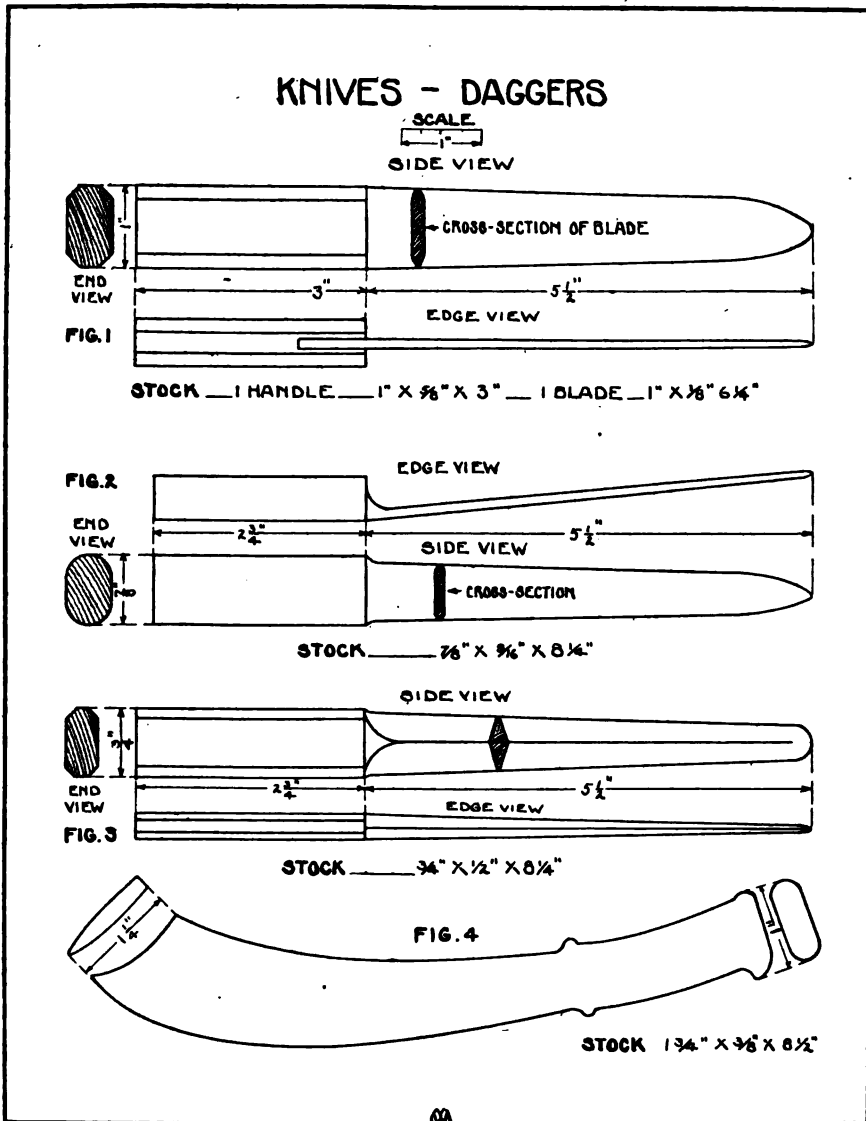

soft. It should be hardened by repeated hammering over the whole surface while resting on a piece of hard wood or metal. The edge should be beveled by hammering and then further sharpened with a file or on a grindstone. It can be polished with emery cloth.



TIP CAT OR PEGGY. The simplest "cat" can be made of a piece of broom handle, 5" or 6" long. A half dozen types of "catties" are herewith suggested. If the numbers are to be dispensed with, the hexagonal and round ones present excellent problems in modeling. The corners of the square ones should be rounded freely, else the continued hard hitting will soon nick up the edges and make them look badly. Lay out the figures before cutting the taper. This will insure a working edge from which to square the lines across.

The game is played as follows: "One player stands within a circle, and with stick or bat of convenient size strikes the cat on the end, making it fly into the air. Before it falls to the ground the batter knocks it as far as he can. If the cat falls within the circle, the batter is out and another takes his place. If the batter makes a fair knock, he guesses how many bat lengths he has sent the cat, that number being added to his score. However, if his guess is too high, as shown upon measurement, he is out. The one having the highest score after a certain number of rounds, wins. The game may be greatly varied. Sometimes the batter measures the distance by jumps; sometimes sides are chosen. In the latter case as many holes are made as there are players on each side. These holes are made equally distant apart and in the form of a circle. One side takes position, one player at each hole, the other side forming outside the circle. One player "tips" the cat from his hole and all run, the object being for each player to get to the next hole before the other side can return the cat

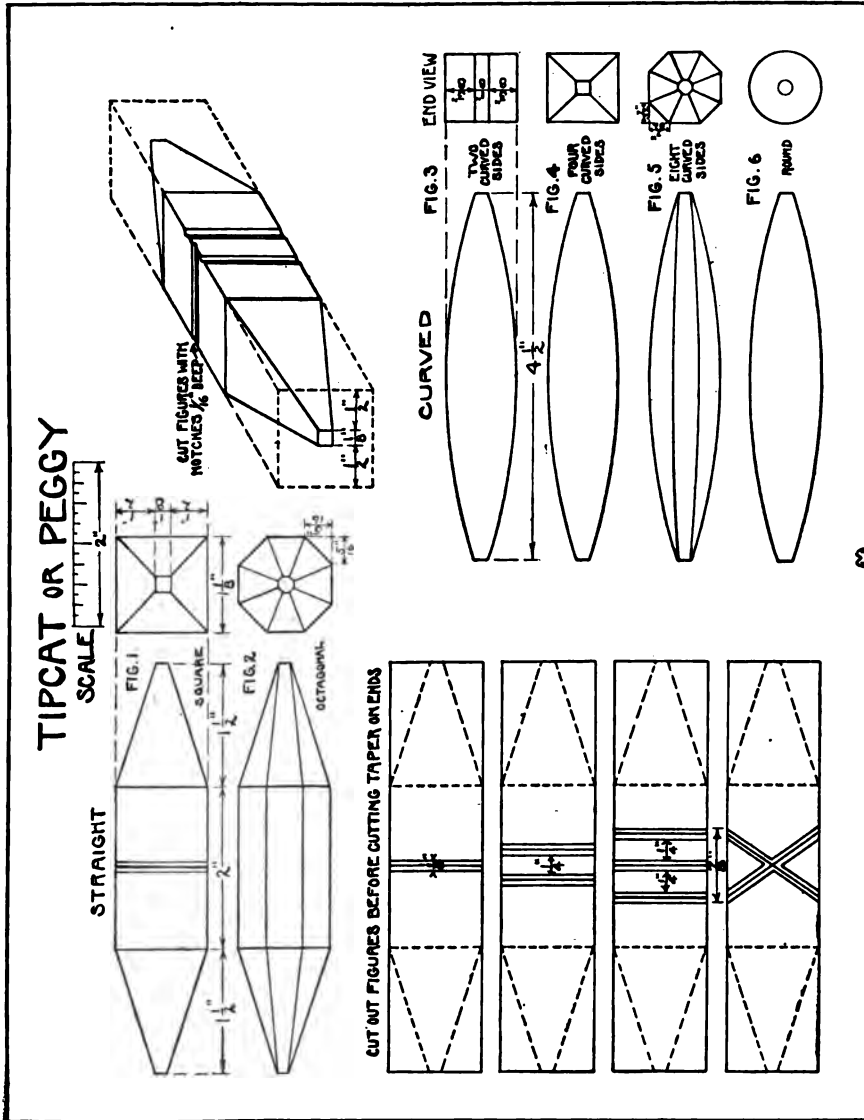

between any two holes. If this is successfully done, the side at the bat scores a run; if not, the side is out. The side scoring the greatest number of runs, wins.”¹

¹ G. E. Johnson, *Education Through Plays and Games*, pp. 173-174.

PEGGY BATS. The peggy bats should not be made of soft wood but an inexpensive hard wood should be used, such as pine or oak, because of the hard usage it is bound to receive. For the same reason the sharpness of all square corners should be well rounded off. Eighteen inches of broom handle is a favorite bat for boys.

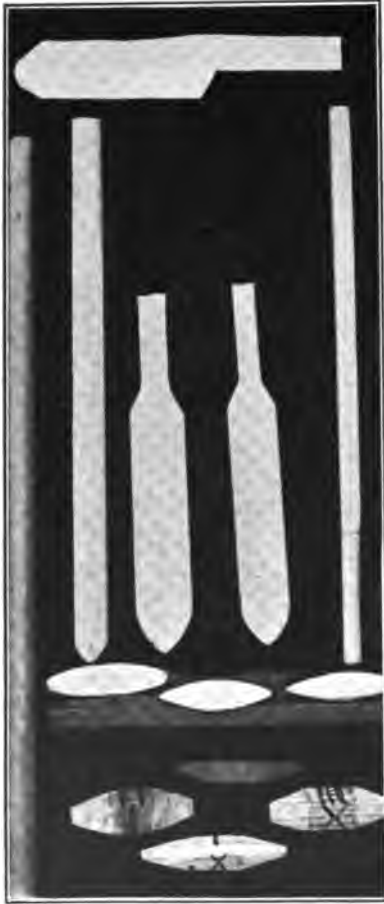

For the manual training man who is looking for a series of tool exercises in round modeling and chamfering, the bat as suggested in Fig. 8 has been found to be most excellent. Figs. 4, 5, and 6 illustrate the method used to model the handle from the square to the round. To do this first lay out the octagonal shape. Gage the lines from the edges a little more than one-quarter the diameter. In this case where the thickness is $\frac{3}{4}$ " the distance should be a full $\frac{3}{16}$ ". After gaging cut to the lines as Fig. 4. Next, make 16 sides as Fig. 5. With large work it is best to lay out all the lines, but with the smaller pieces it is simply necessary to plane off the eight edges and thus make the 16 equal sides. It is then a simple matter to plane off these 16 edges, making 32 sides, and round up with sand paper as Fig. 6.

For chamfered edges such as at the end of the bat, do not make the lines with the marking gage, since the knife marks remain in the wood; but use the thumb gage by holding the pencil between thumb and finger, using the finger as a stop against the work and letting the pencil point project the desired distance. A little practice makes this a very desirable method.

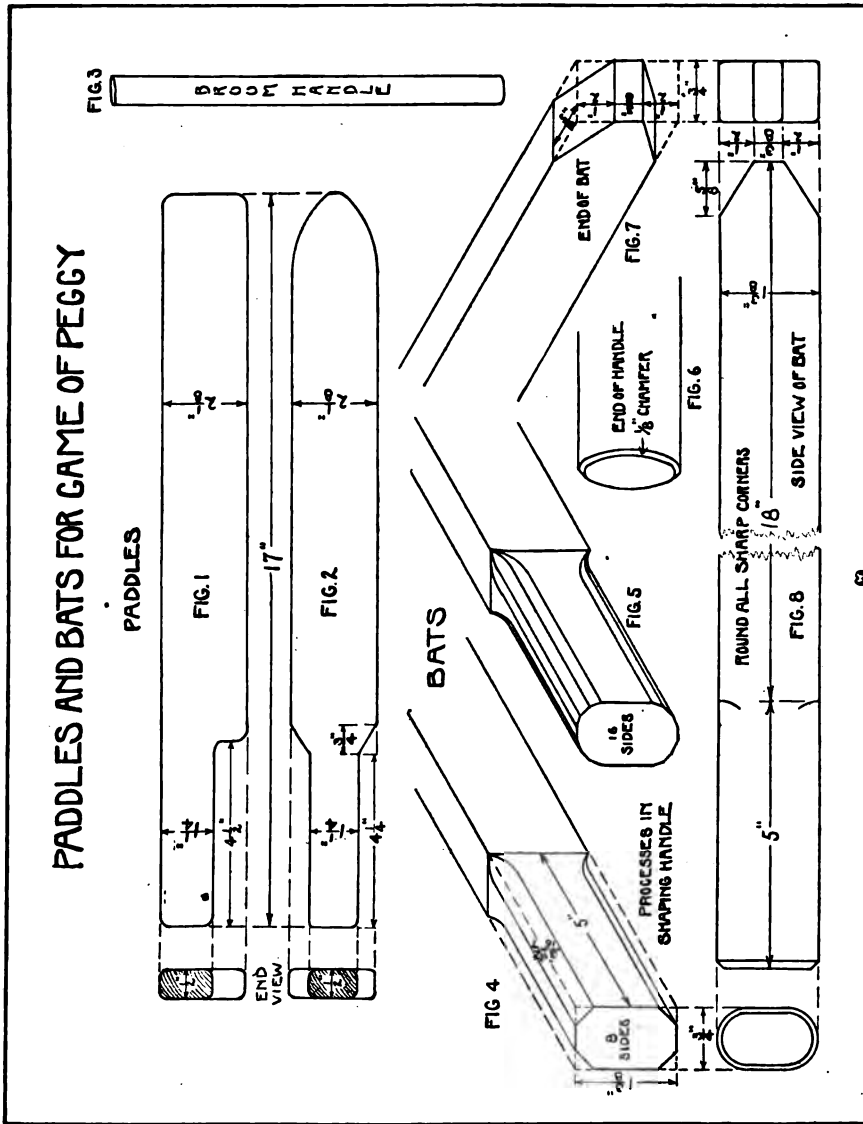
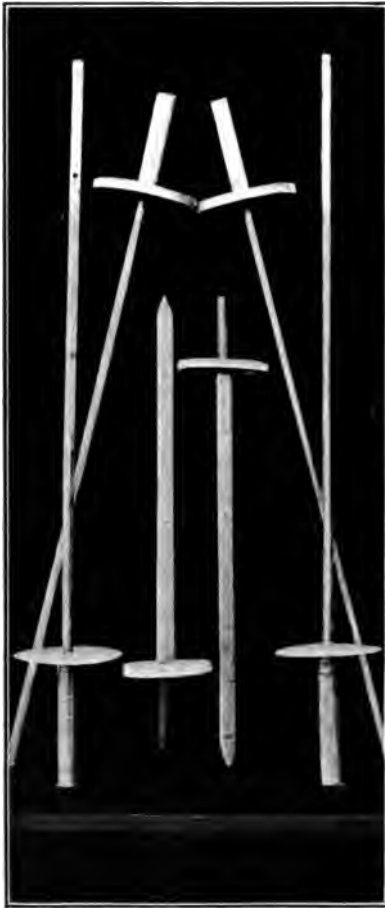

Fig. 8 is the type of bat which meets with universal favor by the boys. For the younger boys and the ones for whom the making of this is too advanced, make the paddles as shown in Figs. 1 and 2.

FENCING RODS. Figs. 1 and 2 are suggestions of fencing rods in which round rods or dowels are used for the blades. If dowels are not available, the blades can readily be made from square or rectangular shaped sticks. The wood for the blades must be perfectly straight grained. They should



be shaped up as shown in Fig. 3. In Fig. 1 the blade tapers from $\frac{1}{2}$ " diameter at the handle to $\frac{1}{4}$ " diameter at the point. The blade of Fig. 2 is tapered in thickness only, as shown in Fig. 4, from $\frac{3}{8}$ " at the handle end to $\frac{3}{16}$ " at the point. The points should be rounded, but not sharpened.

In Fig. 1 a round rod is used for the handle. In Fig. 2 the handle is made from a rectangular piece as shown by Fig. 3. The sharp corners can be sandpapered off. Bore a hole into the end of the handle about 1" in depth so that the end of the blade will fit snugly. Also bore a hole the same size in the center of the guards.

To assemble the fencing rod, first slip the guard over the end of the blade; then, after applying glue to the parts, slip the blade into the hole in the handle. Be careful that this hole is perfectly straight so that

the handle and blade will line up together. Brad the parts together and let them dry thoroughly before using them.

Of the middle pair of rods in the photograph, the blades are made from rectangular pieces shaped up as shown in Fig. 4. The other pairs of rods have been made from dowels, one with wooden guards

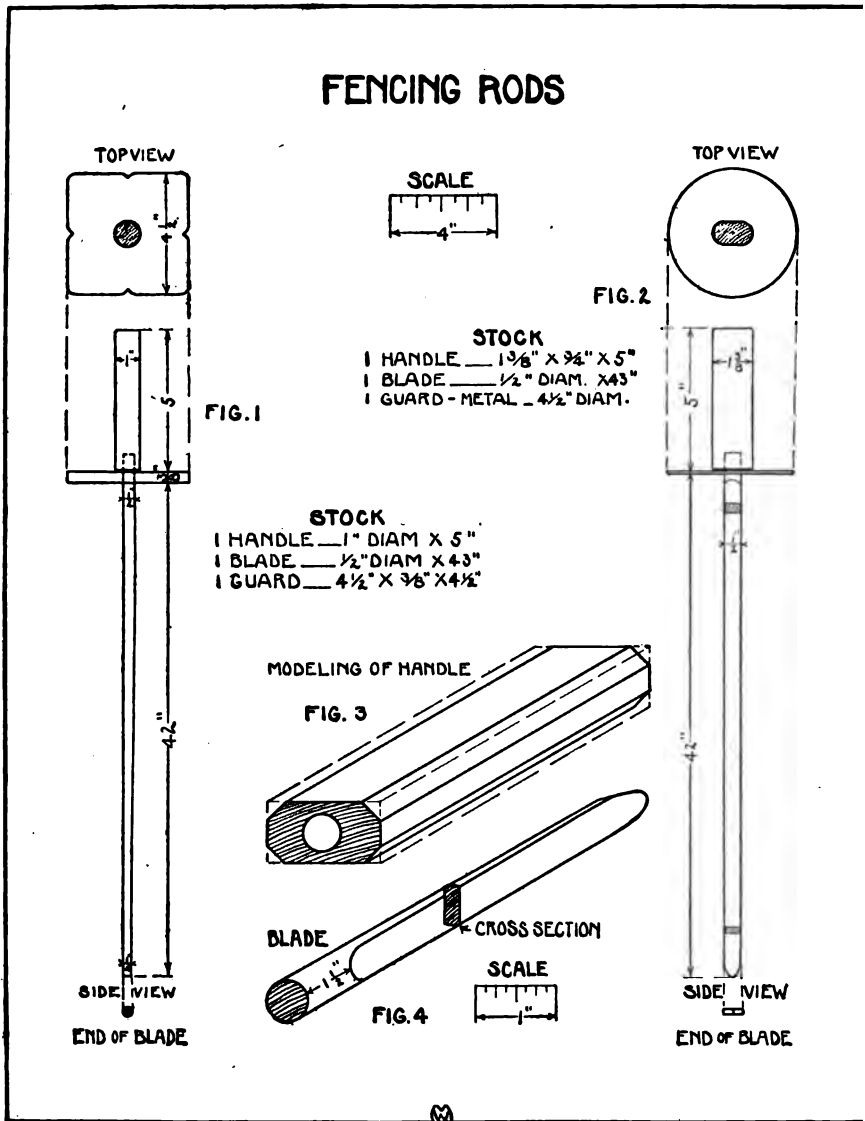

and the other with metal guards. The guards that are shown in use in the other photograph on page xxiv have been found to be very serviceable. These rods are made of bamboo. The large end of the bamboo is used for the handle and the smaller part for blades.



ROQUE OR CROQUET GAME. To play the game herewith shown, place at the stake a perfectly round ball. A large size grain of shot is very satisfactory. Size No. BB is small enough to readily go through the arches. Holding the game board on the palm of the hand, tilt it so that the ball will go through the arches in the order marked in Fig. 1. Should the ball roll into or beyond the boundary groove or gutter, the next player must take his turn. When the first player's turn comes again, he must start the ball from the point where it rolled outside the boundary. The object of the game is to pass through all the arches and finish by hitting the post at the starting point. Fig. 1 represents the usual arrangement of the arches in croquet. Fig. 2 represents a plan of the official roque game drawn to scale. The exact plan and description of the courts are shown in the *Roque Guide* of the Spalding's Athletic Library, published by the American Sports Publishing Co., New York (price 10 cents).

This game board as a manual training problem admits of line carving with and across the grain. In Fig. 1, $\frac{3}{8}$ " holes are bored in the corners and by means of a gouge these are connected with a groove. If this groove is large enough to hold the ball the outside rim or stop may be dispensed with, but it will be found that this rim used as an extra precaution saves the ball from falling off to the floor. The corners of the outside rim can be mitered. The top surface of the board should be smooth. Double pointed tacks can be used for the arches.

The crokinole and carrom boards as shown above were quickly

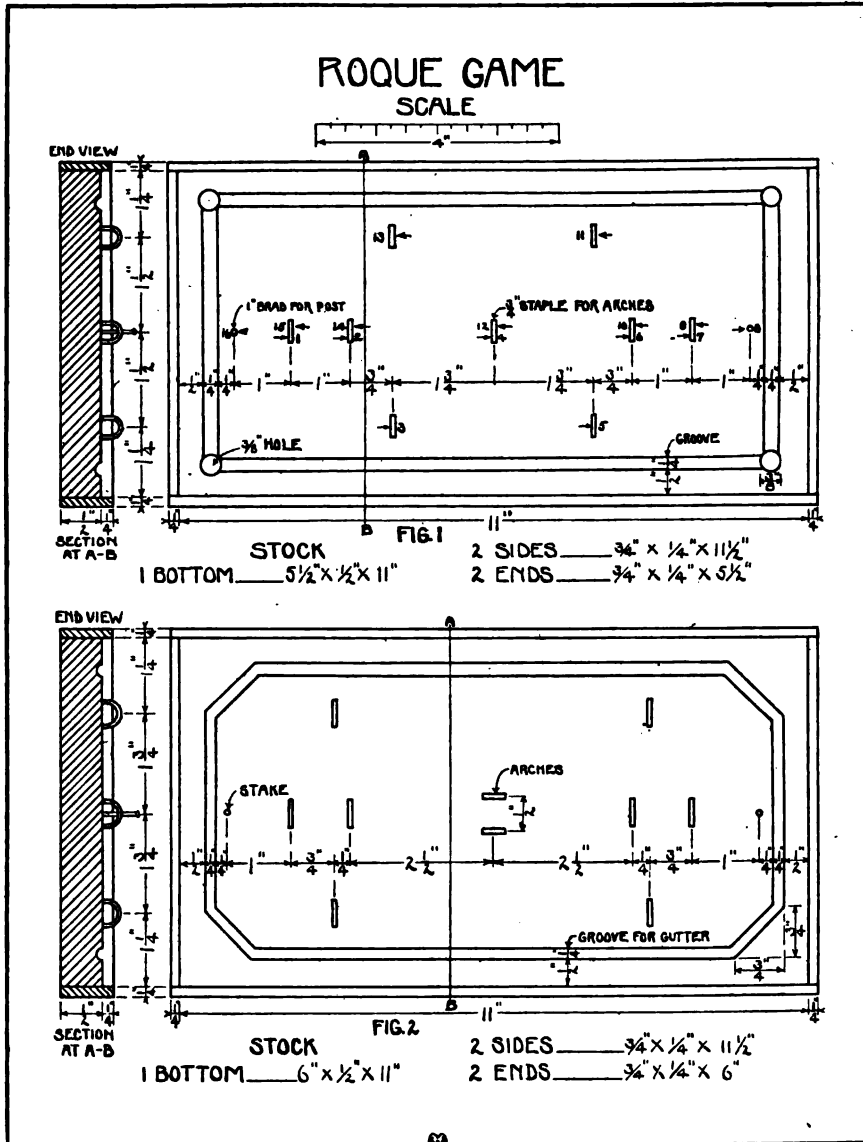

and easily made one-half the regulation size. Although more difficult it is better to make them full size, which is about 30". If possible go to the store and get exact measurements. The game disc is about $\frac{3}{8}$ " high and the outside rim 1".



SOLITAIRE GAME. Dowels, round pins, nails, round discs, or marbles can be adapted to any one of the solitaire boards; square, octagonal, or round as shown in the drawing. If it is desired to make the board of a solid piece as in Fig. 2, the boring can be stopped just as soon as the point of the bit comes through on the bottom side. Great care must be exercised in the boring; for if one hole is bored through, it necessitates boring all the holes through and using a bottom board. If desired, a bottom board can be used as in Fig. 1. In Fig. 3 a countersink bit can be used to make the recesses for the head, or a round-headed screw can be filed up and used as a countersink. This secures a better fit for the marble.

The "Center Hole" game consists in starting with all but the center hole filled, and in finishing with only the center hole filled. The method used is by jumping as in checkers and removing the piece jumped. The key for correct play, as per diagram (Fig. 1) is as follows:

1. Pass D 2 into D 4 and remove D 3
2. Pass F 1 into D 3 and remove E 3
3. Pass E 1 into E 3 and remove E 2
4. Pass E 4 into E 2 and remove E 3
5. Pass C 1 into E 1 and again on into E 3, removing D 1 and E 2
6. Pass E 6 into E 4 and remove E 5
7. Pass G 3 into E 5 and remove F 3
8. Pass D 5 into F 3 and remove E 5
9. Pass G 1 into G 3 and again on into E 5, removing G 2 and F 3
10. Pass B 3 into D 5 and remove C 5
11. Pass C 7 into C 5 and remove C 6
12. Pass C 4 into C 6 and remove C 5
13. Pass E 7 into C 7 and again on into C 5, removing D 7 and C 6
14. Pass C 2 into C 4 and remove C 3
15. Pass A 1 into C 3 and remove B 1
16. Pass D 3 into B 1 and remove A 1
17. Pass A 3 into A 1 and again on into C 3, removing A 2 and B 1

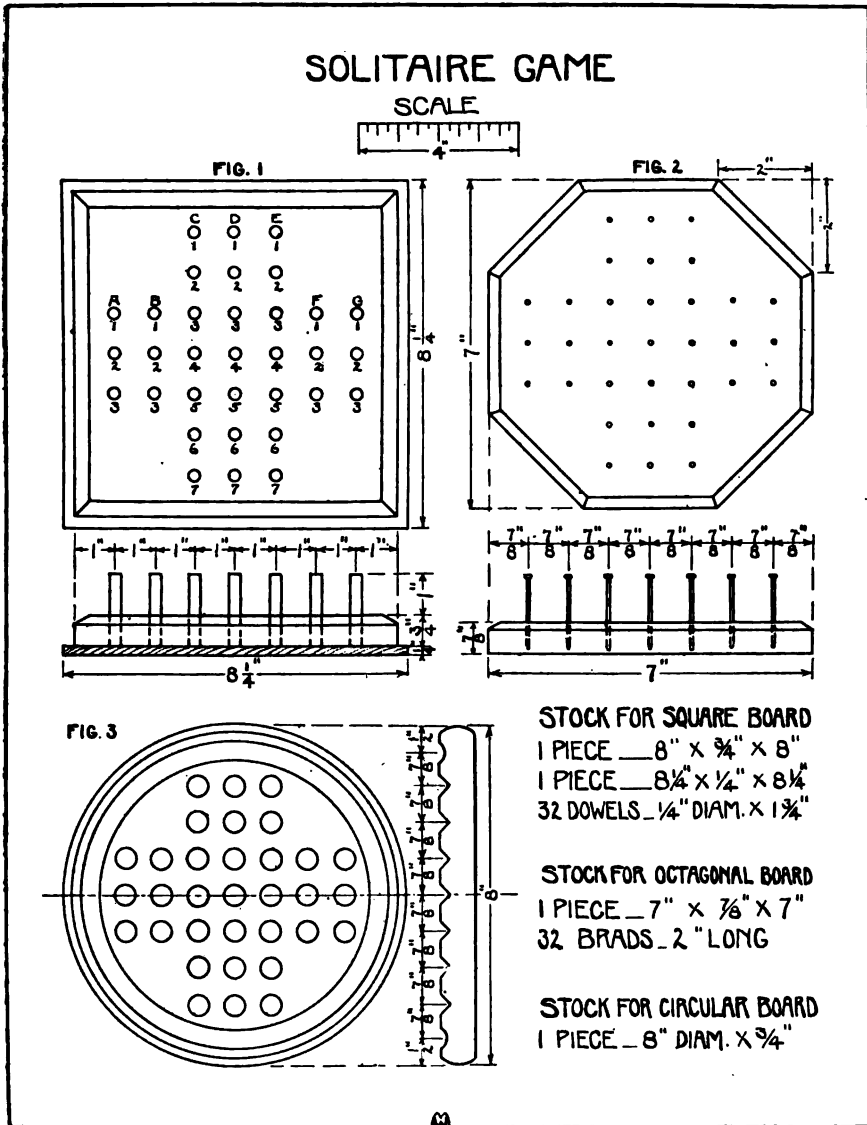

- | | |
|---|---|
| <p>18. Pass D 5 into D 3 and again on into B 1, B 3, D 5, F 3, removing D 4, C 3, B 2, C 5, and E 5</p> <p>19. Pass F 2 into D 4 and remove E 4</p> | <p>20. Pass C 4 into E 4 and remove D 4</p> <p>21. Pass E 3 into E 5 and remove E 4</p> <p>22. Pass F 3 into D 5 and remove E 5</p> <p>23. Pass D 6 into D 4 and remove D 5</p> |
|---|---|

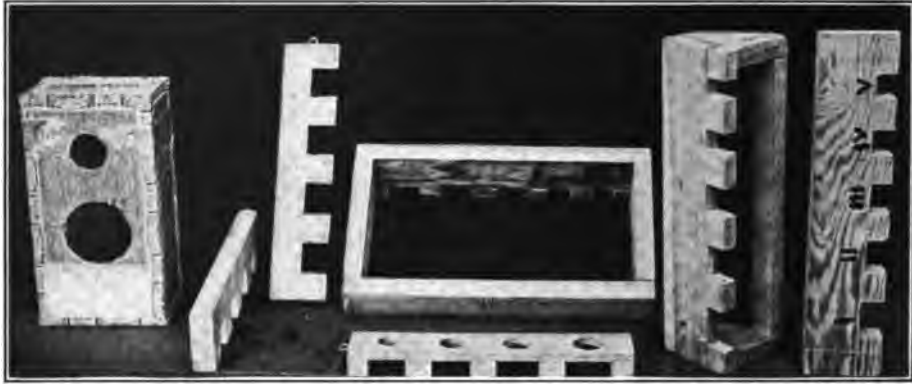

MARBLE GAMES. The marble board or rake may be made in a great variety of ways, covering processes especially in sawing, chiseling, and boring. If thin wood is used as suggested in Fig. 1, the openings should be cut out with a coping saw.

A sawing and chiseling problem is suggested in Fig. 2. The slant on the top edge of the two end pieces can be cut at the same time. After getting them out the proper length and thickness, fasten them together in position with two brads or a clamp, and then cut the slant. In fastening the box together, a few drops of glue should be used at the joints. Considerable care must be taken in nailing, else the pieces will split. Use two nails in the back and two or three in the front. Care must also be used to have the bottom edges on a line with each other, else the box will not set down level. For the slow workers, the making of the ends and back could easily be dispensed with.

Fig. 3 suggests a problem in either chiseling or boring or both. If the chiseling and boring are combined in the one piece as suggested in Fig. 3, the holes should not be bored until after the chiseling is finished. To get a good finish, edges should be slightly rounded or chamfered, and sandpapered.

Fig. 3 in the drawing of bean bag games on page 17 is a suggestion of possibilities of marble rake made from cigar boxes. If the openings are cut with a chisel it must be very sharp and great care must be taken else the wood will split. If it is best to use the coping saw, see directions for use on page xxiv.

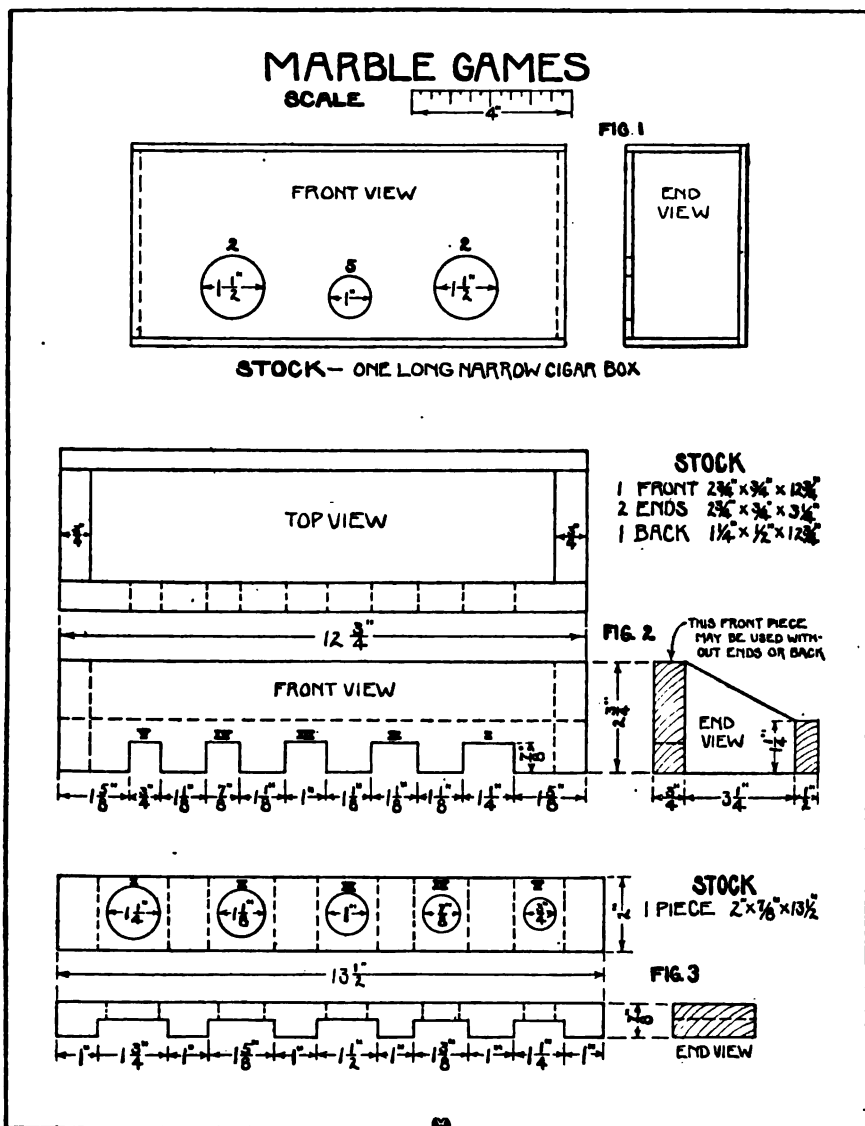

It is best to leave the paper on until after the cutting is done. Points in playing the games may be arranged as desired; one point for the large opening and more as they increase in difficulty. This is suggested in Figs. 2 and 3.

STILTS. Stilts for those who have had no practice in stilt walking should be long enough to fit under the shoulder or to grasp with the hands. The foot should not be strapped to the step. To avoid accidents when falling, one must be able to quickly jump to the ground.



The short stilt strapped to the leg as shown in Fig. 3 should not be used until one has become expert in walking. In some countries, the stilt is much used by shepherds and is a great convenience in traveling over the ground. A strap each for the ankle and the foot fastens it very securely.

When camping out, the stilts may be cut from a tree. Select a straight limb about $1\frac{1}{2}$ " in diameter which has a branch growing out at almost right angles. Cut this branch off with a projection of 3" or $3\frac{1}{2}$ " for the step. Cut the limb off about 20" below this step and the necessary length above.

As a manual training problem, the stilt affords an excellent exercise in rounding the edge and in chamfering. This process is described in the tip-cat bat on pages 60 and 61. A light wood with a straight grain is desirable. To avoid splitting at the ends, a chamfer of at least $\frac{3}{16}$ " should be given the bottom edge. Care must be taken in fastening the step to the upright that the screws or nails do not split the step block. To avoid splitting bore a small hole in the step where the screw enters. Foot loops can be made with bands of thin metal as suggested in Fig. 1, or the foot can be fastened with cords or leather straps. The straps can be

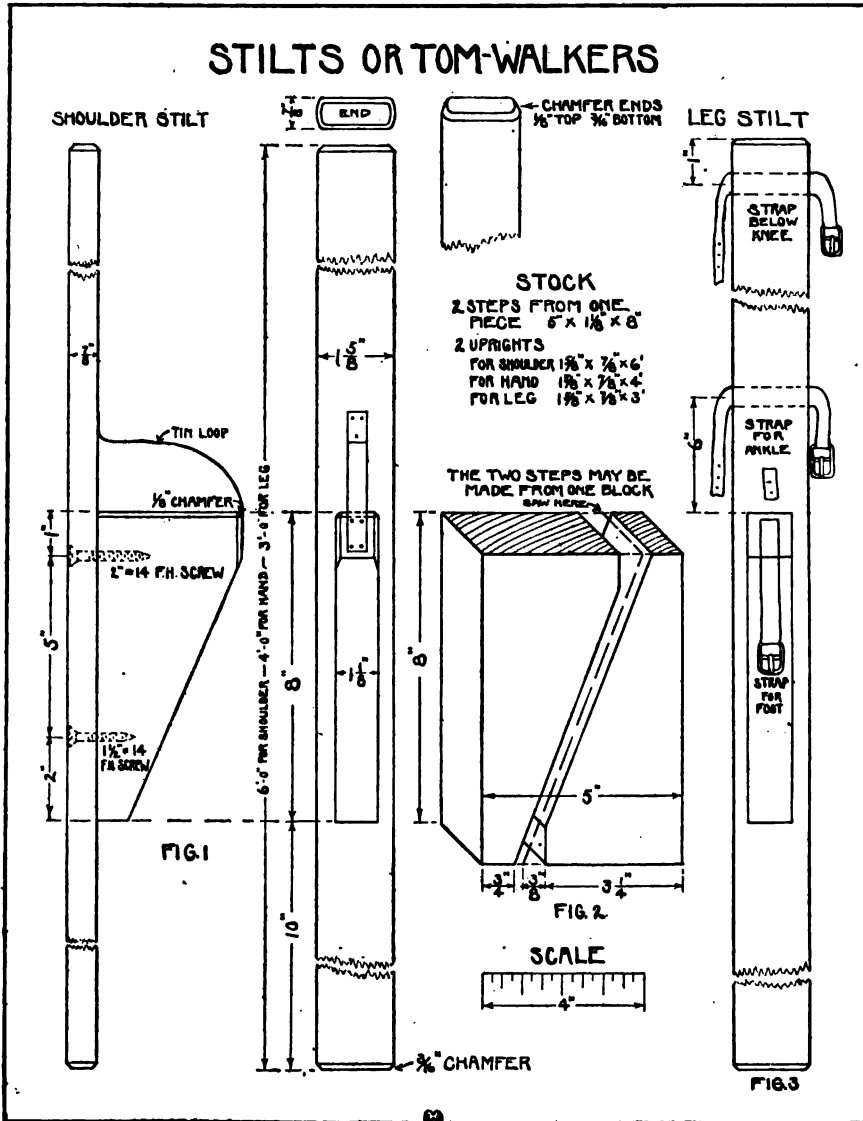

fastened to the uprights or slipped into loops made of leather or thin metal. In Fig. 3 buckles are shown. These can be purchased at the leather store or harness shop. They can easily be sewed or riveted to leather strips about $\frac{3}{4}$ " wide.

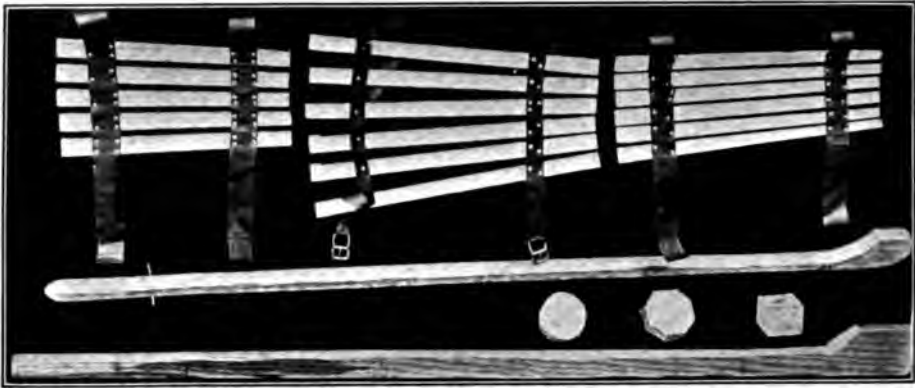

SHINNEY OR HOCKEY STICKS, PUCKS, AND SHIN GUARDS.

Hockey sticks should be not less than 36" and not more than 48" long. An excellent stick can often be selected from the branch of a tree. When made in the workshop, the process of modeling the handle is seen in the drawing of the peggy bat shown on pages 60 and 61. A longer striking surface than that shown in Figs. 3 and 4 is desirable, but is not practical unless the grain of the wood follows the curve of the turn, as would be the case in a piece cut from a tree or when the end is steamed or soaked in water and bent into shape. Short grain must be avoided. The handle should be rounded for at least 18" from the end. For the younger boys and girls the handle should be not more than 1" round or the size given in Fig. 4, while for the older boys $1\frac{1}{2}$ " round or the size shown in Fig. 3.

The pucks can be made any shape or of any material that will roll well. Many prefer the round shape because it rolls.

Shin guards are a necessity. The guards should be made to fit the person intending to wear them. They must be made short enough so as not to interfere with the free movement of the ankle and the knee. The width over all should taper so as to fit the leg. Figs. 1 and 2 are two arrangements which have been found to work out well for boys of the upper grammar grades. To fasten together, lay the strips in position as shown in drawing. Next lay the straps made of strong leather at least $\frac{1}{2}$ " wide and the necessary length, across the strips. Four short nails or tacks about $\frac{3}{8}$ " long should be used to fasten the

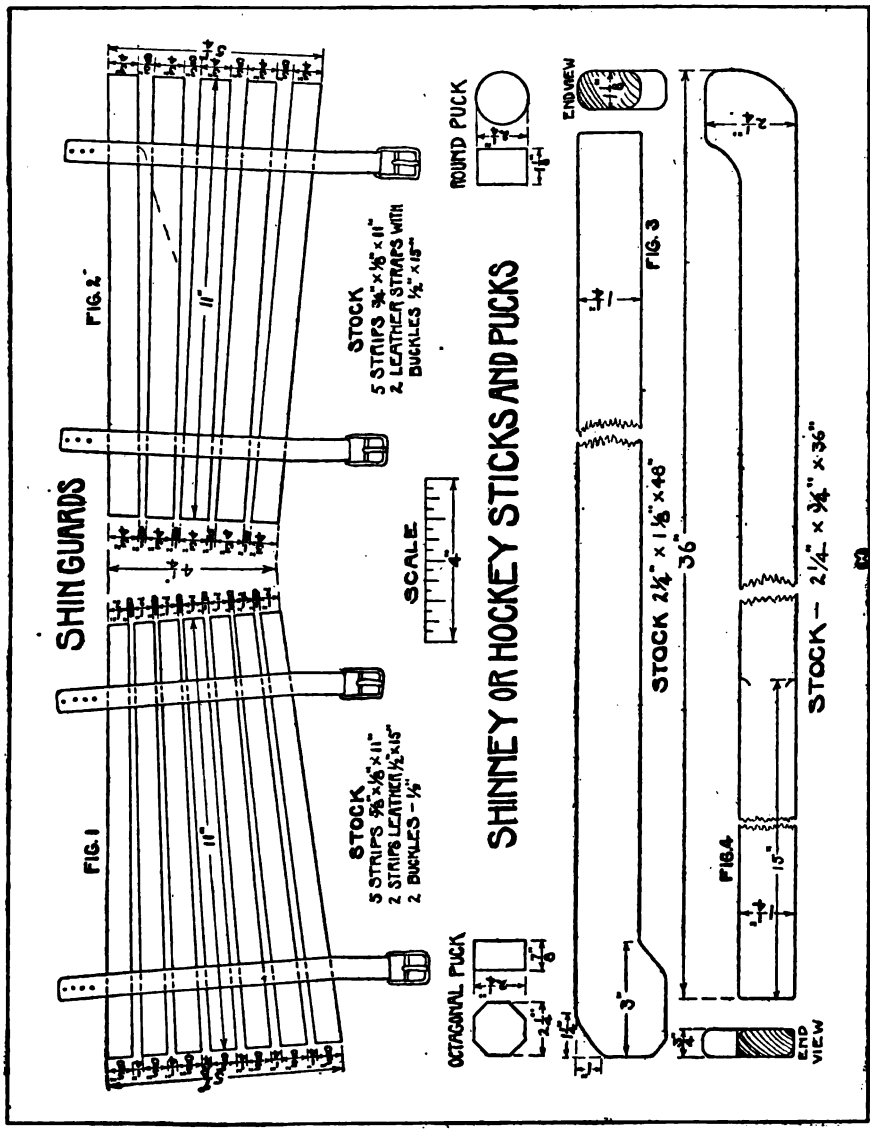

strap on each strip of wood. After all the nails are hammered down tight, turn the shin guard over, and bend the points of the nails over, hammering them down firmly into the strips. Fasten a buckle to one end of the straps, and punch small holes in the other end.



BOW GUN. A straight grained hard wood such as white ash should be used for the bow. A barrel hoop can be used. Cut the strip to the desired width and thickness, and then taper it toward the ends, keeping the bottom edge straight. Just how much to taper it, will depend on the wood used. Test it while working it down. When bent, the bow should make a strong curve with the ends curved more than at the middle. When the cord is attached and pulled back hard, the distance between the middle of the cord and the middle of the bow should be the same as the distance between the trigger and the hole in the barrel in which the bow is held. A heavy fish line or rawhide makes an excellent bow-string. It is well to have this slightly shorter than the bow, and it is best to have it arranged with a knot and loop so that it can be slipped off, thus relieving the bow of the continued strain.

The stock and barrel of the bow gun can be made of one piece, but to save lumber in the construction of Fig. 1 they are each made of separate pieces, the edges being glued up on the line indicated in Fig. 2. Before gluing them together, the hole for the bow should be cut. It is well to make the hole small enough so that the bow will fit tightly. After gluing the stock and barrel together and cutting to the outline, lay out the slot for the trigger and cut it out with an auger bit and chisel. Then cut a semicircular groove along the upper edge of the barrel as shown by the end view of the barrel in Fig. 2. If this is too difficult, the groove can be formed by fasten-

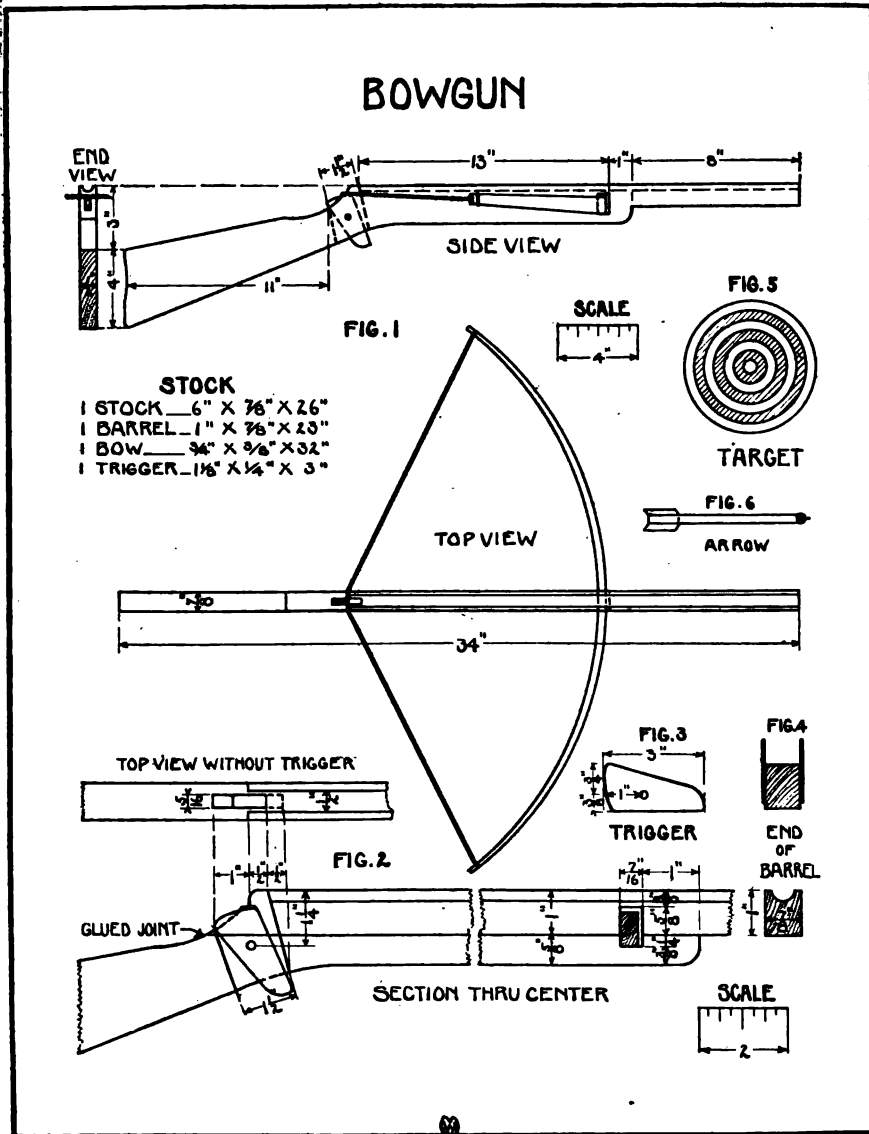

ing pieces of metal or thin wood on the sides of the barrel as shown in Fig. 4.

If the cutting of the groove and slot is too difficult, the gun can be made of three thicknesses of wood by using three $\frac{1}{4}$ " or $\frac{5}{16}$ " pieces

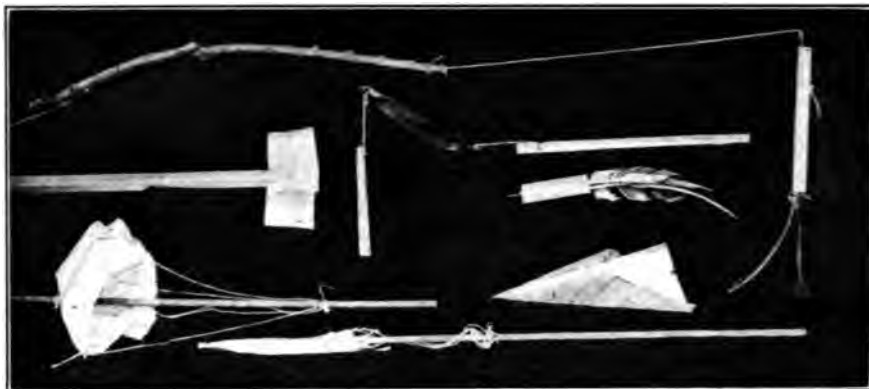

the full size of the gun. After sawing the outline, take the inside thickness and cut enough away to allow for the slot of the trigger and the groove of the barrel.

Cut out the trigger and fit it in so that, when cocked, it assumes the position shown in Fig. 2. When the trigger touches the back of the slot, the top of it should rest just underneath the cord as shown in Fig. 1. Next, slip the bow in place and with a brad driven in from the top edge of the barrel, fasten so as to keep the bow exactly in the middle. Now string up the bow and set the gun by pulling the cord back and slipping it down against the shoulder just above the trigger. When the trigger is pulled the cord should readily be raised above this shoulder, thus releasing the tension of the bow. If everything is properly adjusted the arrow should easily shoot 100 to 200 feet with a fairly true aim.

Arrows should be made with the front end slightly heavier than the back. This can be done by forcing a little metal in the end or by wrapping it with wire, or a strip can be cut lengthwise from a shingle. Into the rear end, a paper rudder or feathers should be inserted so that the arrow will carry straight to the mark. To put in the paper guide, the end should be split slightly and a piece of stiff paper slipped in. If feathers are used select straight ones and tie them on with fine wire. A brad should be driven in the front end and filed to a sharp point. This will enable the arrow to hold where it strikes the target. This point should stick out only slightly, otherwise it is rather dangerous.

A target as suggested in Fig. 5 can be made of soft wood or heavy cardboard. The alternating circles should be painted in contrasting colors. Targets are also made with a dirt or sand background by using a shallow box and covering the top with a target painted cloth or very tough paper.

DARTS. The illustration on the opposite page shows a few of the many possible varieties of darts. In the upper part of the photograph two methods of dart throwing are shown. In the top one a stick made from a green bough is used, and in the one below it a heavy rubber band is used to give the needed elasticity. To hold the cord a notch is cut in one side near the front end of the dart. This notch must be cut out on a sharp bevel slanting inward toward the front end, and in such a manner that a knotted cord will be held tightly in place when the cord is pulled forward, but releases itself when the cord is pulled in the opposite direction. In both of the above the cord is knotted and is seen caught in the notch of the dart. In the upper one the dart is hanging downward at the extreme right; while in the lower one the dart is horizontal and the handle hangs downward. In this one the dart is simply a small round stick with the forward end slightly larger and heavier. The proper length of the cord must be determined by experimentation. The longer the stick the longer must be the cord.

To throw the dart grasp the handle of the stick in the right hand (unless left handed) and with the dart in the left hand pull hard making the cord taut and the stick bowed. Now release the dart, and with a quick motion of the arm throw the stick forward. The sudden straightening of the stick and the added momentum given it by the movement of the arm will throw the dart with considerable force a great distance.

In the dart thrower in which a rubber band is used, the rubber is tied to the handle with a piece of cord. Practically the same movements are used in throwing as previously described. With practice these darts can be thrown at a target with gratifying results. The boys and girls enjoy this sport immensely.

SWISS DINKEY BIRDS. In Fig. 1 is shown the arrangement of the pivots and the cord of the pendulum which swinging sets the head and tail in motion. The pivots should be located near the upper corners of the body, and the ends of the cord should be fastened to the inner ends of the head and tail by means of a hole or a nail. The pivots must work very freely, and the cords must be arranged so that no friction is created to retard the free working movement of the parts. If desired two body pieces can be used, and thus the movement of parts can be hidden from view. The upper part of the leg can be fastened inside the body pieces. By fastening the stand to the side of the leg piece, the stand can be placed on a table and a book or other object can be used to hold the bird up in position, as shown in the front view of Fig. 1. The leg piece can be dispensed with, as shown by the lower figure in the photograph. The cord for the pendulum should be long, and the weight heavy enough to exert a strong pull.

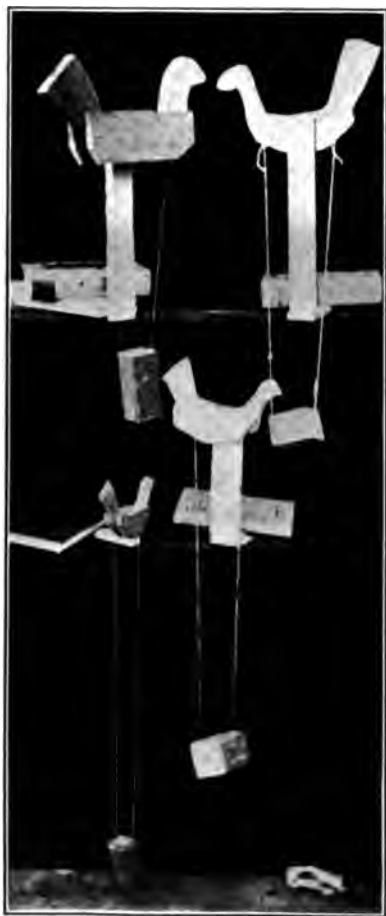

The leg piece can be dispensed with, as shown by the lower figure in the photograph. The cord for the pendulum should be long, and the weight heavy enough to exert a strong pull.

The body of Fig. 2 is made of one piece. In each end of the body is cut a slot within which the head or tail piece is allowed to pivot. The

legs are made of two dowels which are fastened to a block or stand piece. An opening of an inch or more is cut on one side of this stand and it is fastened to a table top by means of a wedge as shown in the front and side views of Fig. 2. In Fig. 1 the cord swings freely, but in Fig. 2 with every swing of the pendulum the cord strikes the project-

SWAYING FIGURES. The principle underlying the movement of these figures is the familiar arrangement of the knife and pencil as shown in Fig. 2. The "honest woodsman" (Fig. 1) can be outlined and sawed out with the coping saw. One edge of the upright piece

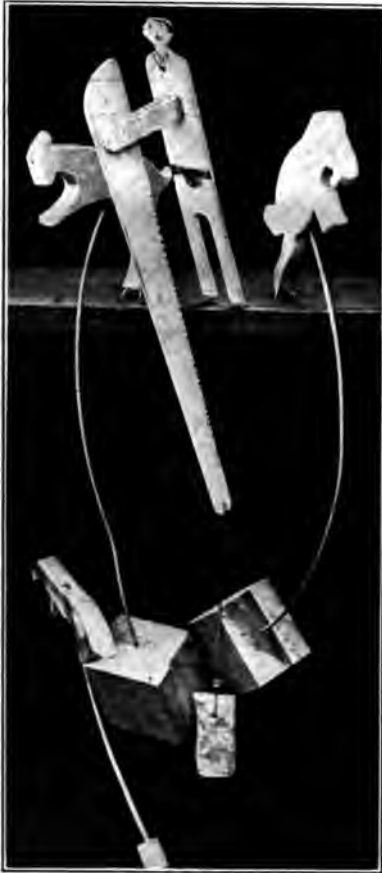

is notched to resemble saw teeth. The arms can be made of two pieces. They can be nailed to the sides of the saw, and the body can be nailed directly to the ends of these arm pieces, or the ends can be set into the body piece as suggested in Fig. 1. If nailed directly to the body, the arm pieces should be larger, about $\frac{3}{8}$ " or $\frac{1}{2}$ " thick, so as to avoid splitting. One method of construction is to make the arms of one piece with a slip joint at one end and a mortise and tenon joint at the other, as is shown in the lower part of Fig. 1. The pivots set in the bottom of the feet are made by driving in brads and filing the brads to sharp points. It is necessary that these points be of equal length. If variations in the proportion of the parts are made, it will be found that the longer the saw and cord and the shorter the arms, the more upright will be the position of the body. The weight should be fairly heavy.

The dancing elephant (Fig. 3) is a suggestion that might be applied to many animal forms. The whole figure can be made of one piece as suggested in Fig. 3. The figure of this elephant is simply the modification of a rectangular piece. The animal can be made much more interesting and better proportioned if the body and head are made

FALLING SEESAW AND LADDER. In making the zigzag pole for the falling seesaw or teeter, shown in Fig. 1, care must be taken in getting the width of the zigzag even. The end of the pole can be nailed and glued to the base pieces, and the upright pieces can



be cross-lapped or simply crossed. The seesaw as shown is made reversible. When the beam has worked down to the bottom, turn upside down and the beam will work down again. The figures must pivot loosely on the nail, and the lower part of the figure must be heavier than that above the pivot, so that they will always right themselves with heads up when the seesaw is turned upside down. The side brace is not shown in the photograph, but has been found necessary to make a strong piece of work. A little wax will enable the beam to work with less friction. Within certain limitations the pupils can each cut and draw their own figures.

The falling ladder or falling chinaman shown in Fig. 2 and in the lower part of the photograph can be worked to any size desired. It is highly important that the project-

ing nails be placed evenly. As with the seesaw, a little wax will avoid friction. The rungs and sides of the ladder are usually drawn on a flat piece of wood, but cross-lap joints can be made if a real ladder is desired. Have the nails project far enough for the figure to run between the heads of the nails and the front surface of the ladder. If desired, the figures for both these problems may be cut out of heavy cardboard.

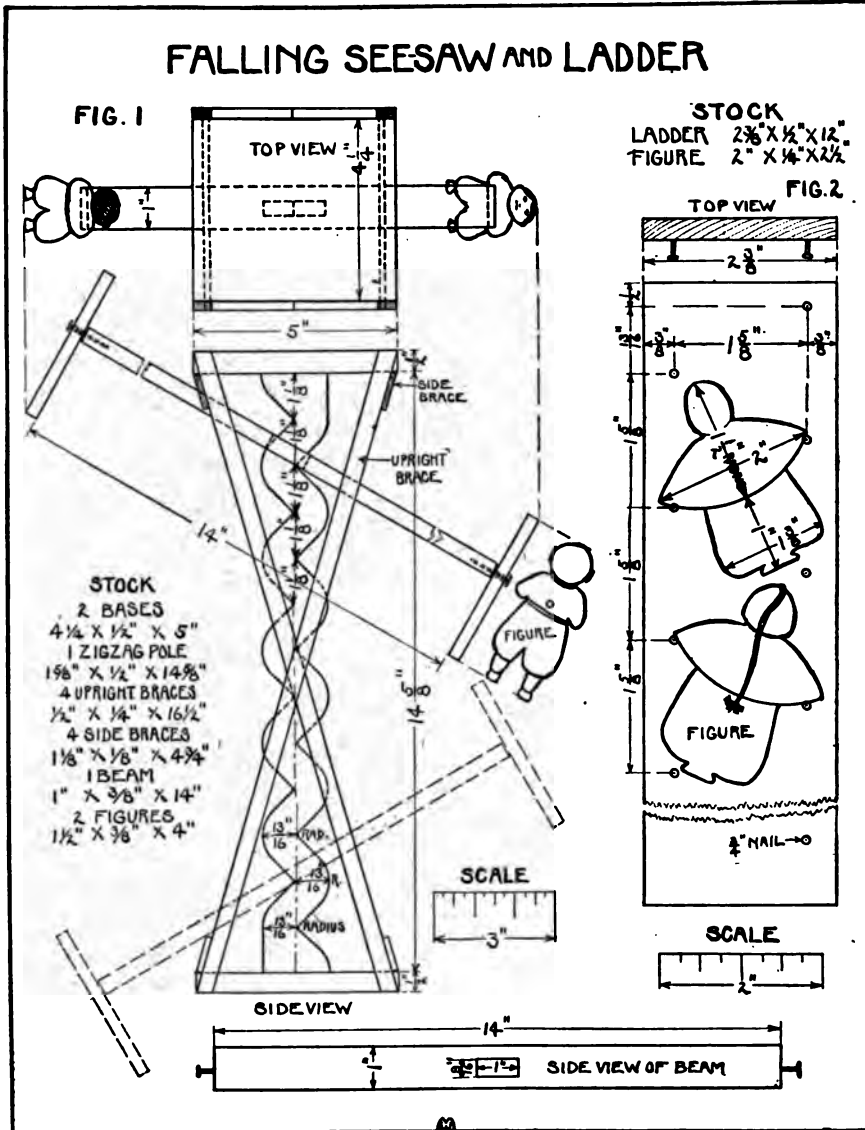

Be sure to get the curve for the chinaman's cape perfectly even, with both sides exactly alike. The ladder can be made longer, but the position of the nails must not be changed unless the dimensions of the figures are made larger or smaller in exactly the same proportion.



LOOMS. The simplest form of a loom can be made of a piece of cardboard with ends notched to catch the warp threads. A simple wooden loom is made with butt joint as shown in Fig. 2. A lap joint is shown in Fig. 1. A packing box may also be used by driving nails in two parallel edges of the open end.

To hold the warp threads in place, make saw grooves or drive in nails. The grooves can be sawed in both pieces at the same time by fastening them together in the vise. The position of all grooves should be marked off from the rule without moving it. This insures having the correct number of grooves within the desired length. Fig. 1 shows the grooves made with the saw. They should be not less than $\frac{1}{4}$ " apart. Care must be taken in sawing the grooves. They must not be more than $\frac{1}{8}$ " in depth, else the wood between the grooves will be liable to break out. If brads are used, they must be driven in carefully lest the great number of them on a line split the wood. In Fig. 1 steel rods $\frac{1}{8}$ " or $\frac{5}{32}$ " in diameter, located just under the outside threads, are used to keep the cloth a uniform width. If wires are not used, considerable care must be taken to keep the cloth the same width throughout.

The loom as planned in Fig. 2 is made with a butt joint by nailing the cross pieces to the ends of the side pieces.

The loom should be designed to suit the widest size of cloth desired; the full width or length, however, need not be used. After the cloth is woven, slip the thread off, then cut and tie the ends two at a time.

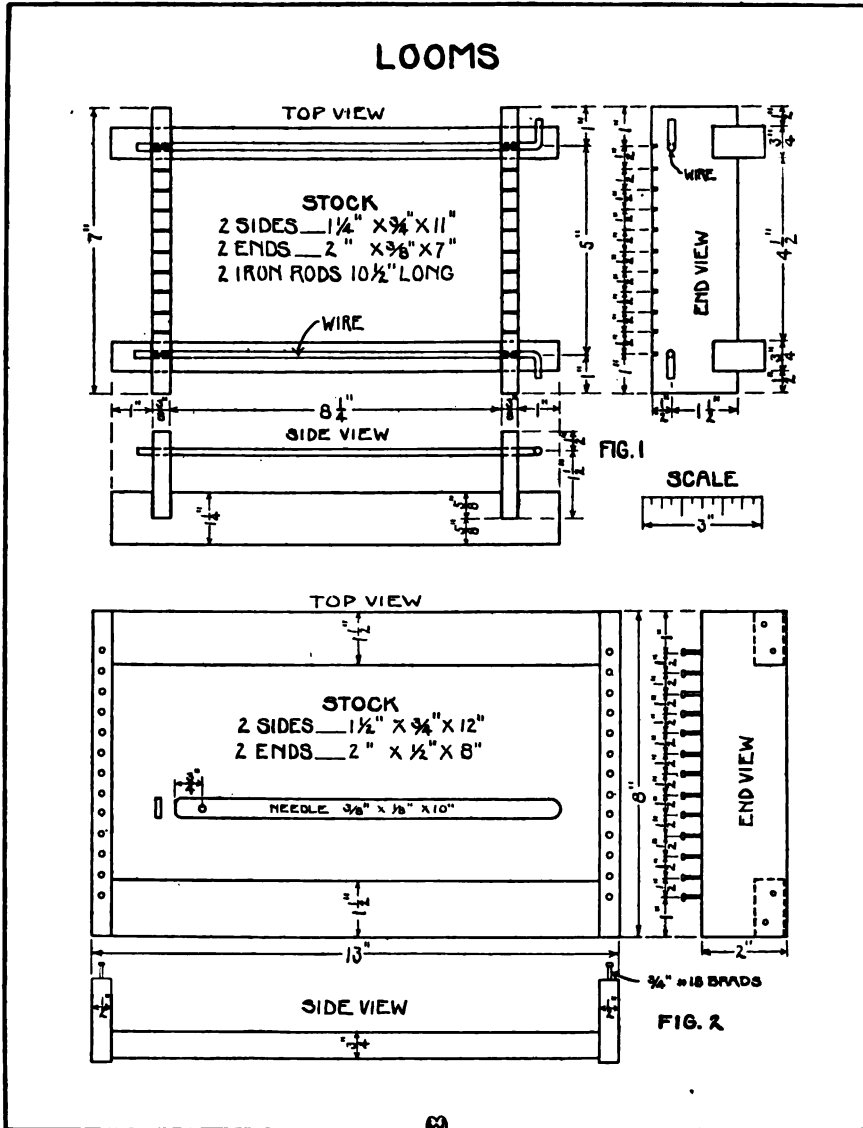

The threads running lengthwise are called the warp, and the threads crossing these are called the woof or weft. A strong string or fine cord such as carpet warp should always be used for the warp threads; while raffia, yarn, or cord may be used for the woof.

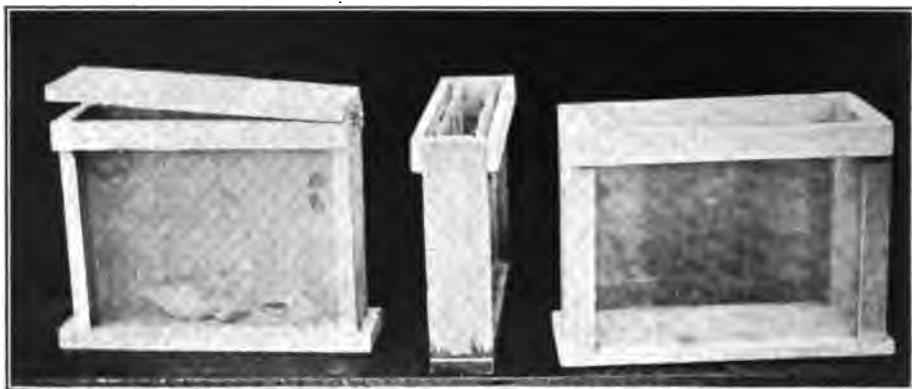

ROOT-CAGES. The root-cages herewith suggested are wooden frames with glass sides. In Fig. 1 the glass is set into grooves sawed in the bottom and the end pieces. The grooves can be very quickly cut if a circular saw can be used; but, if this is not available, an ordinary hand saw can be used. Old photograph negatives serve economically for the glass sides. The film can be readily cleaned off by putting the negative in a hot water solution of sal soda or other alkali and then scraping.

To construct the root-cage suggested in Fig. 1, slip the glass into the grooves of the end pieces, hold them firmly in position, and locate the braces. Then slip the glass out and nail on the braces. Next slide the glass in place again, mark the location of the bottom, slip the glass out, and nail the bottom in place, after which slip the glass in place again. It should fit in tightly, so that if the cage is turned upside down the glass will not drop out. A strip can be nailed lengthwise along each side at the top to hold the glass in place. If the root-cage is to be used for a vivarium, a cover should be provided. For this purpose a piece of perforated sheet metal or wire screen should be fastened down over the top. If hinged this can be used as a door. A nail driven and bent over will serve as a catch. If used for plants, a piece of cardboard should be slipped up against the glass sides to exclude the light, otherwise the light will drive the roots away from the glass.

Fig. 2 shows a simpler construction of root-cage. No grooves are used, the edge of the glass fitting closely against the surface of the

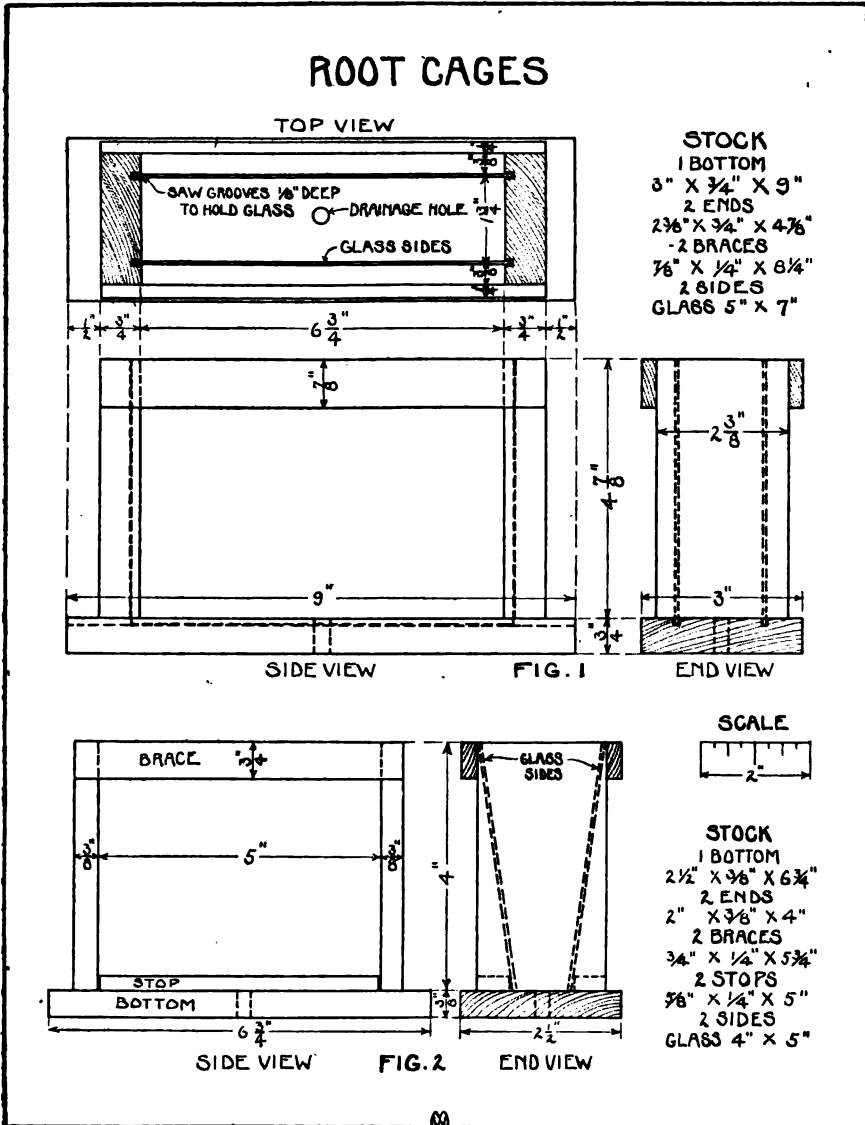

wood. Nails are used to hold the glass in place, but a strip of wood is much better. In Fig. 2, strips of wood are suggested along the bottom edges. To prevent the glass from slipping out if the cage is turned upside down, a thin strip should be fastened across the top at each end.



BIRD HOUSES. A simple bird house can be made from a jar or can, as suggested in Fig. 1. A back piece should be attached to the bird house if it is to be fastened against an upright surface; or it may be suspended by means of wire or cord as suggested in Fig. 2.

Many various types of construction may be used for the house, one of which is suggested in Fig. 2. The house may be built up of sticks of wood like a log cabin. The roof can be thatched or shingled.

A box can be used as shown in the photograph. If the box is large, partitions can be put in and in this way compartments can be made to accommodate a number of birds. One opening only should be made for each compartment so that the inhabitants can keep out intruders. A hole not more than 1" in diameter should be used for wrens and chickadees, and 2" for bluebirds and robins. If large birds such as doves are to be housed, the opening should be about 3" by 4". The interior of the house can be readily accessible by hinging the side. A peephole can be arranged to observe the habits of the birds. It is desirable to have the surface of the wood rough.

The following suggestions are by an authority on the care of birds. "The proper size for a bird house is 6" square floor space and 8" high. Old weathered boards should be used, or if painted they should be made the color of an old tree trunk. A single opening near the top should be made, 2" in diameter for most birds; although for wrens and chickadees one with 1" diameter is sufficient.

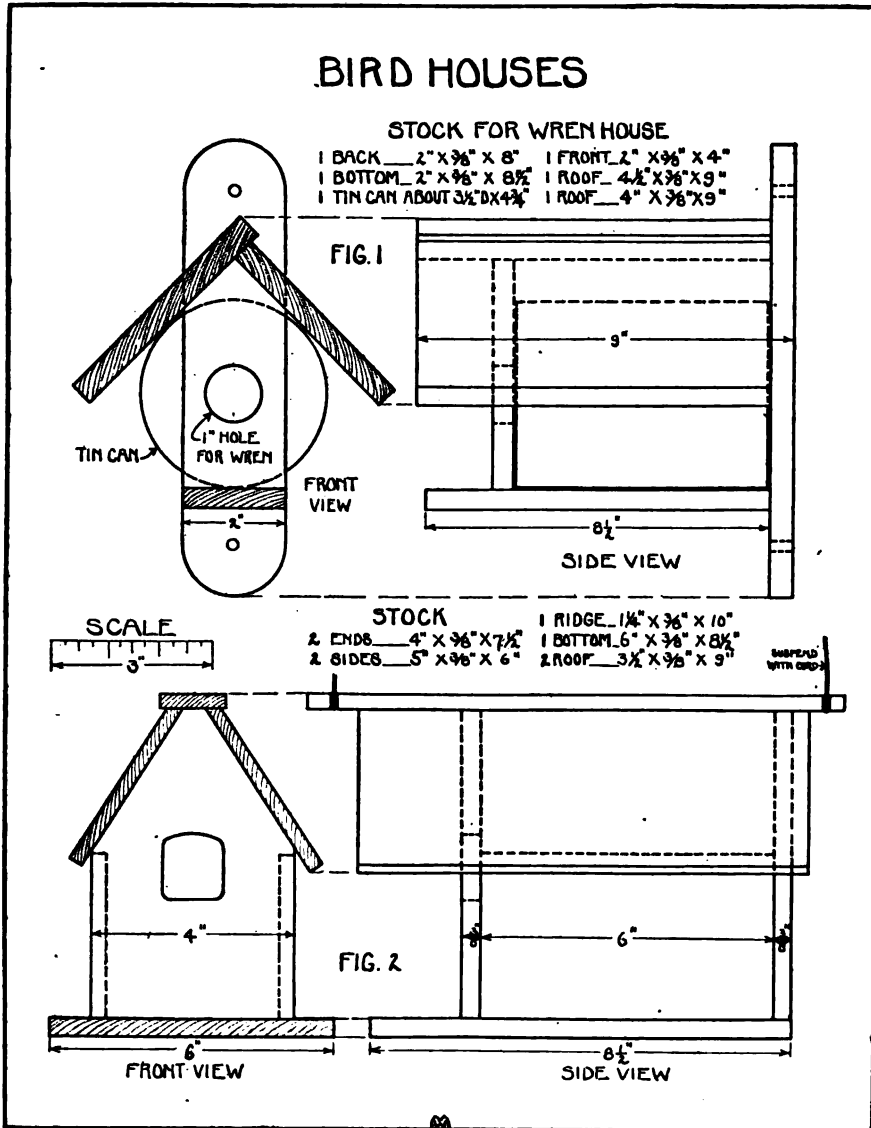

“A house of this kind will serve to keep out English sparrows, and for wrens the house should be set in a shady place.”¹ For descriptions of bird houses, see Wm. Noyes' *Design and Construction in Wood* and A. F. Siepert's *Bird Houses Boys can Build*.

¹ Hodge, *Nature-Study and Life*, p. 334.

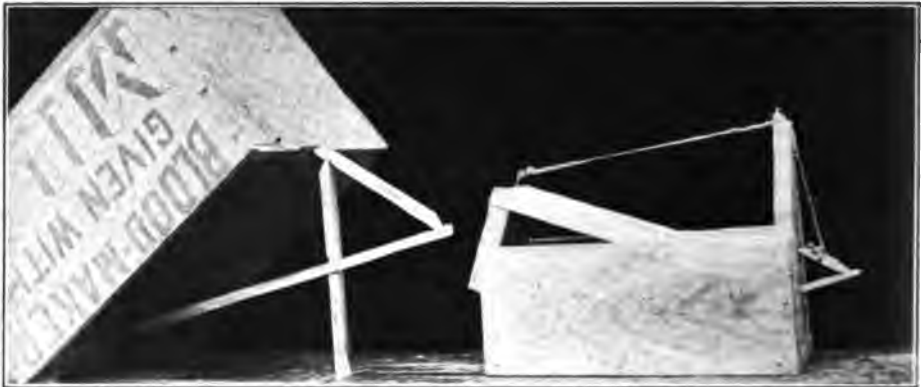

BOX TRAPS. The box traps herewith shown are planned for rats or mice. If desired for mice only, reduce to one half the sizes given. If desired for rabbits or squirrels, they should be made about twice the sizes given. The box made of metal is more durable than wood. Small packing boxes, a convenient size, can be used, and the whole interior of the box can be lined with metal. If so, this should be tacked in before assembling. If the box is not lined, strips of sheet iron or tin should be run around all the open edges, and the holes provided for the trigger and for ventilation. In Fig. 1 the catch is fastened to the under side of the box. The door and catch may be made of one piece. If so, the top piece should be made about three inches longer and tapered so as to catch the end of the trigger. Note that the top edge of the back is beveled for clearance so as to allow the top piece to be raised up high enough to catch the trigger. If a butt hinge fastened to the back and the under side of the lid is used, this bevel is not necessary.

The trigger can be made of a strip of wood, metal, or a wire; the one suggested in Fig. 1 is of wire, and the other two are of wood. The trigger is best made of metal, because if the animal is in the box any length of time the end of the wooden ones will be gnawed up. The hole in the back of the box should only be large enough to insert the trigger.

When the rodent is caught put the box in a bucket of water for a few minutes to drown it. If kept in the water long, it will take a

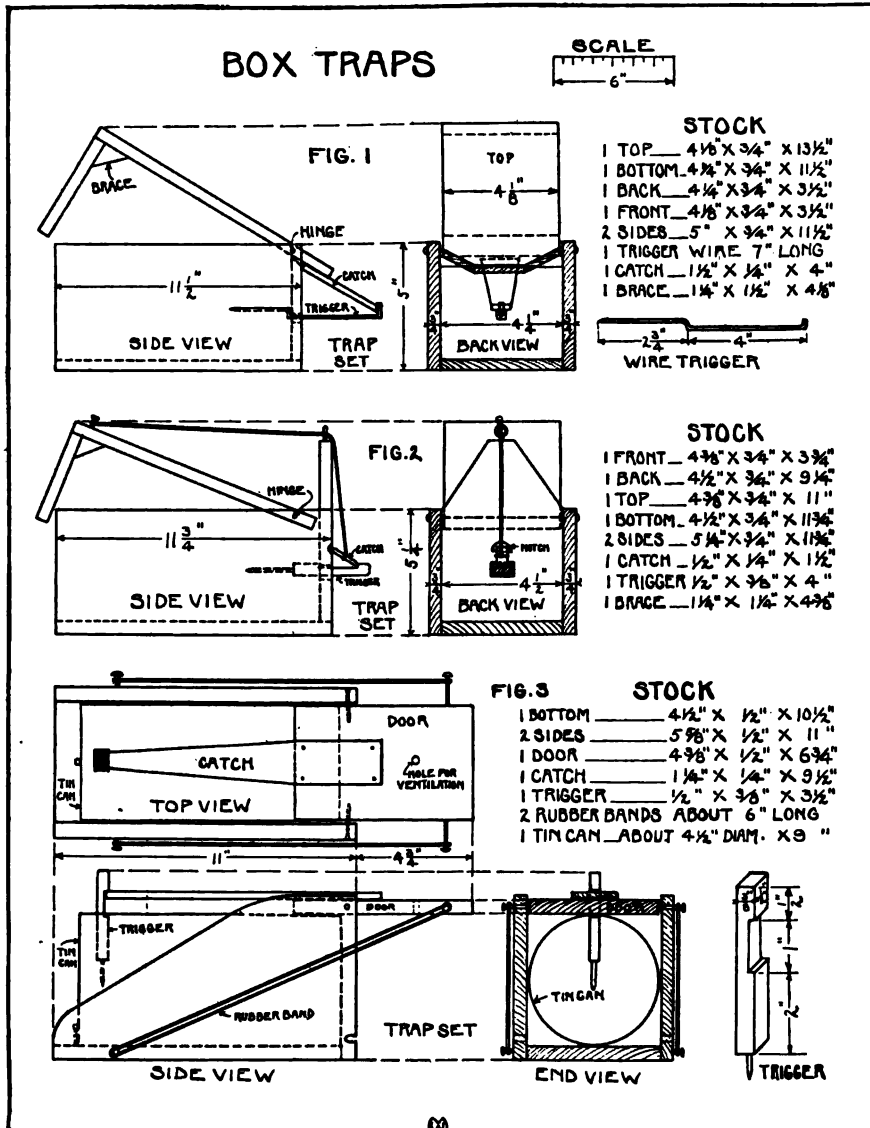

long time for the wood to dry out. To have the box open and shut easily, the top and front pieces are made $\frac{1}{8}$ " narrower than the inside of the box. Note also, that the grain of wood in the back and front pieces runs up and down, that is, in the same direction as the top and

bottom pieces. This is done so that all of the pieces when wet will swell equally in width, and thus allow the box at all times to open and shut easily. A little wax should be applied to the sides if they stick in the least.

The construction of Fig. 2 is almost similar to Fig. 1. The connection between the catch and trigger is made with a string run through a screw eye fastened at the top of the back piece. To hold the upper end of the catch, a notch which is cut in the middle of the back piece is indicated in Fig. 2. A little piece of wood may be fastened to the back instead of cutting the notch. The under edge of this piece will hold the catch down in place. Drive a nail into the end of the trigger and sharpen it to a point so that the bait can easily be fastened to it. If the piece of wood for the trigger is long, the end of it may be sharpened instead of using the nail. In Figs. 1 and 2, as soon as the trap is sprung by a movement of the trigger, the top and front pieces fall down into place and the rodent is securely caught, unless it has a chance to eat its way out.

In Fig. 3, a tin can is used for the box. Pieces of wood are used at the sides and bottom and a brad is used at the end to hold the can up into place. The door pivots at the top by means of nails driven through the sides at the top corner. Rubber bands slipped over projecting nails on each side connect the door to the side of the box. A slight movement at the bait end of the trigger will spring the trap and the rubber bands will bang the door shut. The whole box can be put in water. This is not necessary, however, if the heads of the nails which hinge the door are left projecting and are loose enough to pull out. Pull out the nails, slip off the rubber bands; and the can and door can be lifted out together. Lower it into a bucket of water with the lid in place and against the side or bottom of the bucket; then slip the door away. This method avoids soaking the trap in the water when drowning the rodent.

Another kind of box trap can be made, somewhat similar to that shown in Fig. 3 on page 91, without the use of the rubber band, the door dropping in place by means of its own weight. Either style of trigger can be used. If a box is used a slot can be cut in the top near

the end large enough for the door to fit. If a tin can is used as suggested in Fig. 3, the sides can be made longer and strips or nails put on the inside to form grooves for the door, which must fit loosely so as to drop quickly as soon as the trap is sprung. A strip of wood or stiff wire is used for the connecting bar between the trigger and the door. At one end it fits into the notch of the trigger as shown in Fig. 3. At the other end it fits into a notch or shallow hole (this can be bored with a drill) on the inside surface of the door. A narrow strip of wood or projecting wire fastened to the top near the middle supports the bar, which in turn holds the trigger and door in position when the trap is set. A slight movement at the bait end of the trigger slips the bar out of position, and causes the door to drop down into place. After the rodent is caught the can can be lifted, with door in place over the end of the can, and slipped into a bucket of water as suggested at the bottom of page 92.

The barrel trap which is shown on the left of the illustration on page 26 is made by means of tying a piece of heavy wrapping paper over the open top of a barrel. Food should be put on top of this paper for a few nights so that the rats get in the habit of feeding there. After they have gotten the habit, make slits in the paper. The paper should be stiff enough to hold their weight until they get near the center, when they will drop through the slits into the barrel, and the paper will go back into place. The food must be fastened to the paper so that it will not fall into the barrel. In a large warehouse where several of these traps were set hundreds of rats were caught in one night.

A small trap constructed somewhat like the above can be made from a tin can. Select a large baking powder or coffee can, one with a lid made of thin tin. Make two cuts across the center of the lid at right angles to each other as shown in the illustration on page 26. The opening must be made so that the rodent can easily slip through it to secure the bait put inside, but cannot get out because the edges of the tin slant inward. The rodents that are caught can be drowned by placing the can in a bucket of water, and afterward taken out by removing the lid.



RING TOSS GAMES. The ring toss game, or quoits, is applicable to many tool exercises which involve the cross-lap joint, vertical boring, lathe turning, and box construction.

Fig. 1 is one type of a box construction. An empty packing box with lock corners can be used. Saw the box to the desired height and then nail the top and bottom on. Next saw this box in two, thus separating the bottom and lid. Put lock blocks in each corner as suggested in Fig. 1, or run a thin strip all around the inside of the box, letting it project about $\frac{1}{8}$ ". Bore holes for the pegs or uprights through the top of the box and part way into the bottom. The pegs can be fastened in permanently, or the pegs can be slipped out and put inside of the box together with the rings as shown in the photograph.

Fig. 2 represents a cross-lap joint and the use of 5 pegs.

The use of human or animal figures, such as the tossing of a collar or hat-shaped ring on the figure of a clown which has been sawed with a coping saw or turned on the lathe, the tossing of a bracelet or ring on the outstretched arm of a figure of a woman, or the tossing of a rope ring, or lasso, on the head of animal figures, all such add interest to the making. Group problems can be worked out by having one large figure and several small ones fastened to a board base.

Rings can be made of a variety of materials. Rope $\frac{1}{2}$ " or $\frac{3}{4}$ " in diameter can be shaped and spliced in the form of a ring, and sewed or wrapped with cord or raffia. For a 5" ring, use 18" of rope and splice the ends for 2" or 3". If wire is used, it should be more than

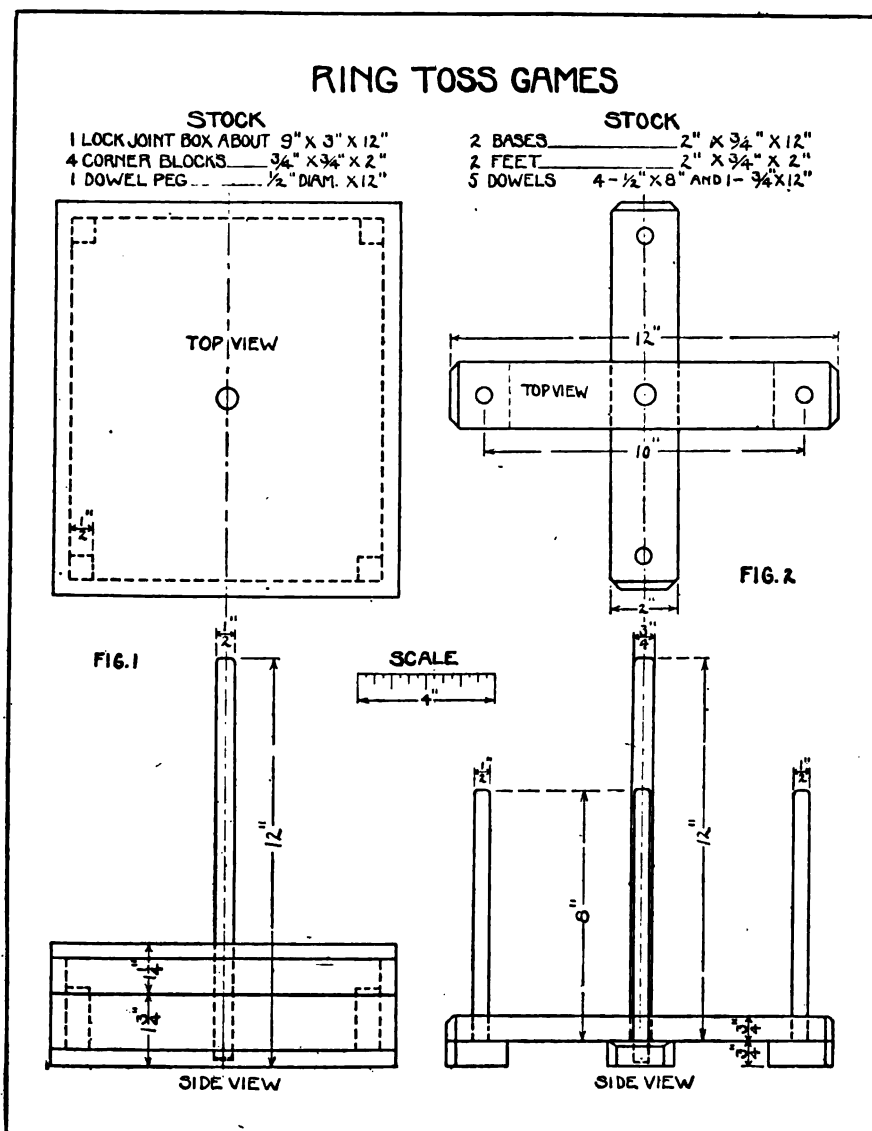

$\frac{1}{8}$ " in diameter so as to be heavy enough to carry well. Rings of wood can be sawed out with the coping saw or turned up on the lathe.

A pattern for quoits can be made and cast in metal. If of iron, a 5" or $5\frac{1}{2}$ " disc with a 2" or $2\frac{1}{2}$ " hole and $\frac{1}{2}$ " in thickness is a good size.



RATTLERS. The ratchet for the clicker as shown in Fig. 1 can be made with any number of teeth. To make the eight-tooth ratchet as herewith shown, select a piece of wood not too thick so that it can be cut out with the coping saw, cut it to $2\frac{1}{2}$ " square, and lay out with center lines each way and also diagonals. These lines will cut the surface up into eight equal parts. With a pair of compasses or dividers draw circles for the base and outer edge of the teeth, and next lay out the teeth similar to the ratchet shown in Fig. 1. The center hole for the axle should be bored before cutting it to shape. The ratchet must fit tightly to the axle. To lay out a ratchet with six teeth, first lay out the circles and then divide into six equal parts. This can be done by stepping the radius six times around the circumference of the circle. The radius of any circle will always go around the circumference just six times. The ratchet can then be laid out and cut to shape as before. The most convenient ratchet is that made from a spool as shown in Fig. 2.

After the ratchet is finished, make a piece long enough for the handle and washer all in one; then find the center at each end and bore holes $\frac{3}{8}$ " or $\frac{1}{2}$ " in depth just large enough for the axle to fit in neatly. Now, saw the lengths for the handle and the washer one off each end, and cut the axle the desired length, which must be the outside thickness of the box plus the depth of each hole previously bored into the handle and the washer. The reason for these dimensions can

holes, but be careful not to get any wax on the axle, else it may make it impossible to securely fasten the ratchet to the axle. Next slip one of the side pieces on the axle, and then fasten the ratchet very securely to the axle. Now nail the two blocks to this side piece. The thickness of the blocks will depend on the thickness of the ratchet; they should be slightly thicker than the ratchet. Next fasten the remaining side piece in place, and then fasten the washer securely to the end of the axle. A nail or cotter pin can take the place of the washer. Now nail the back piece in place. The end of it should be slipped up close to the ratchet, but not close enough to touch. Next fasten the front strip in place. It is best to make this of a wood that does not split readily. Slip one end of this front piece up toward the ratchet so that the point of the teeth will lift the free end, and as soon as it clears the point of the teeth it will bang back into position as shown in the side view, Fig. 1. If set too far up, the strain on the front piece is soon liable to split it into pieces. This strip must be nailed securely to the long block at the end, but not to the short block in the middle. Before fastening it securely, it is well to first tack it lightly in place and test it to see if it clicks satisfactorily. If necessary, the back piece can be dispensed with. The advantage of this piece, however, is that the hollow box thus formed gives a greater volume of sound.

The spool rattler shown in Fig. 3 is made by simply taking an empty spool, running doubled cord through the center, and fastening it around one side as seen in the drawing. Next, take a small stick, slip it between the two thicknesses of cord and twist it tightly by means of the stick. This is shown in Fig. 3 and in the photograph. The tension of the cord pushes one end of the stick tightly against the spool. By pushing the upper end down and then releasing it, a tapping effect is produced. If this arrangement is attached to a hollow cylinder or box, a greater volume of sound can be obtained.

Fig. 4 is the drawing of a rattler stick or "bone." Two or three of these comprise a set. They are held between the fingers and rattled in the palm of the hand. Two modifications of these can be seen in the drawing.

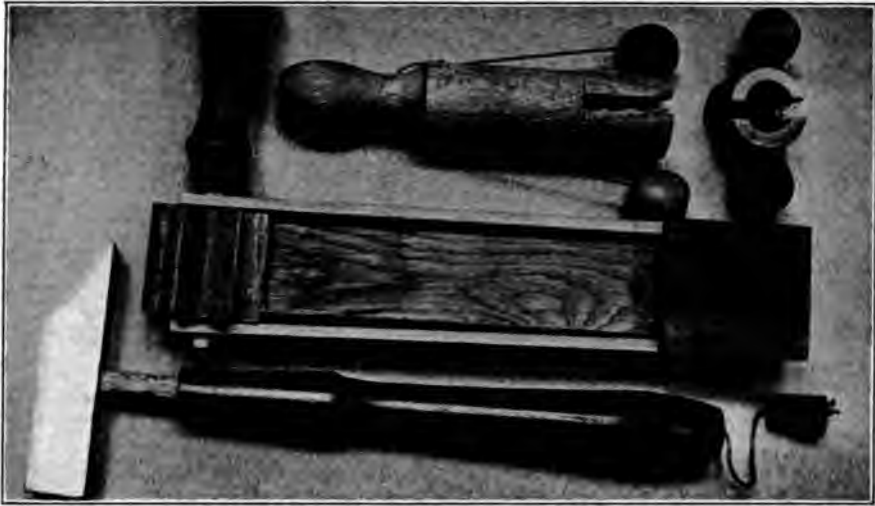

For the smaller rattler shown above, of which both the end and side views are seen, take a $1\frac{1}{4}$ " round or square block and bore a large size hole about 2" deep in one end to make it resonant. Next cut a slot about $1\frac{1}{2}$ " long and $\frac{1}{4}$ " wide in this end. The handle can be shaped up round. Next take an 8" length of wire that is not too soft. Steel spring wire is best. A wire stay from a corset is excellent. Now bore a small hole through the diameter about 4" from the bored end. Slip the wire in this hole and fasten it down to the sides with double pointed tacks about $\frac{1}{2}$ " from where it projects from the hole. The ends of the wire should stand off from the block about an inch as shown above. Fasten on two pieces of wood or metal for the tongues. Holes can be bored and the wire inserted, or they can be tied or tacked on.

Another form of rattler is what is known as a "Chinese drum." It is simply a small hollow cylinder or prism made of a heavy strong paper into which, before it is sealed, are put some small hard particles such as peas or shot.

The lower piece in the illustration, which is a pop gun, speaks for itself. When the piston is pulled out, the cork at the end of the string is set into the end of the hole; and when the piston is pushed in sharply the air forces the cork out with a popping sound. If the piston fits snugly but not too tight, a little practice makes it pop.



AËROPLANE AND GLIDER. Buoyancy and balance are essential requirements in the construction of aëroplanes and gliders. The strips for the aëroplane, Fig. 1, should be made of bamboo splints. If bamboo is not available, a light-weight straight-grained wood such as spruce or white pine should be used. Cut the pieces to the desired size and tie the corners of the plane frames with a fine thread. Slight indentations or notches where the thread crosses will keep the pieces in place. After the frames are made, cover them with a light-weight cloth or thin tough paper. Oiled silk which is sold by the druggists is best because it is waterproof, but it is rather expensive. The frames should be fastened to the center beam in the same way that the corners were fastened together. A few spots of glue will help to hold it firmly. After this is dry attach a cord from the front corners to the center beam and pull taut until the corners of the front plane are raised as shown in Fig. 1. By means of propellers and a rubber band for the motive power, an aëroplane can be made such as is shown in the center figure of the photograph. The propeller, of a thin metal, can be made as suggested in Fig. 4 on page 35.

The construction of the glider shown in Fig. 2 has been suggested by Mr. Hackett, Supervisor of Manual Arts, Reading, Pa. The rudder and planes should be made of stiff, tough paper. Slot the end of the shaft and insert the rudder; then, with glue and nails, fasten the planes to the center shaft. The forward or smaller one should be turned up slightly, and the back one hollowed as shown in

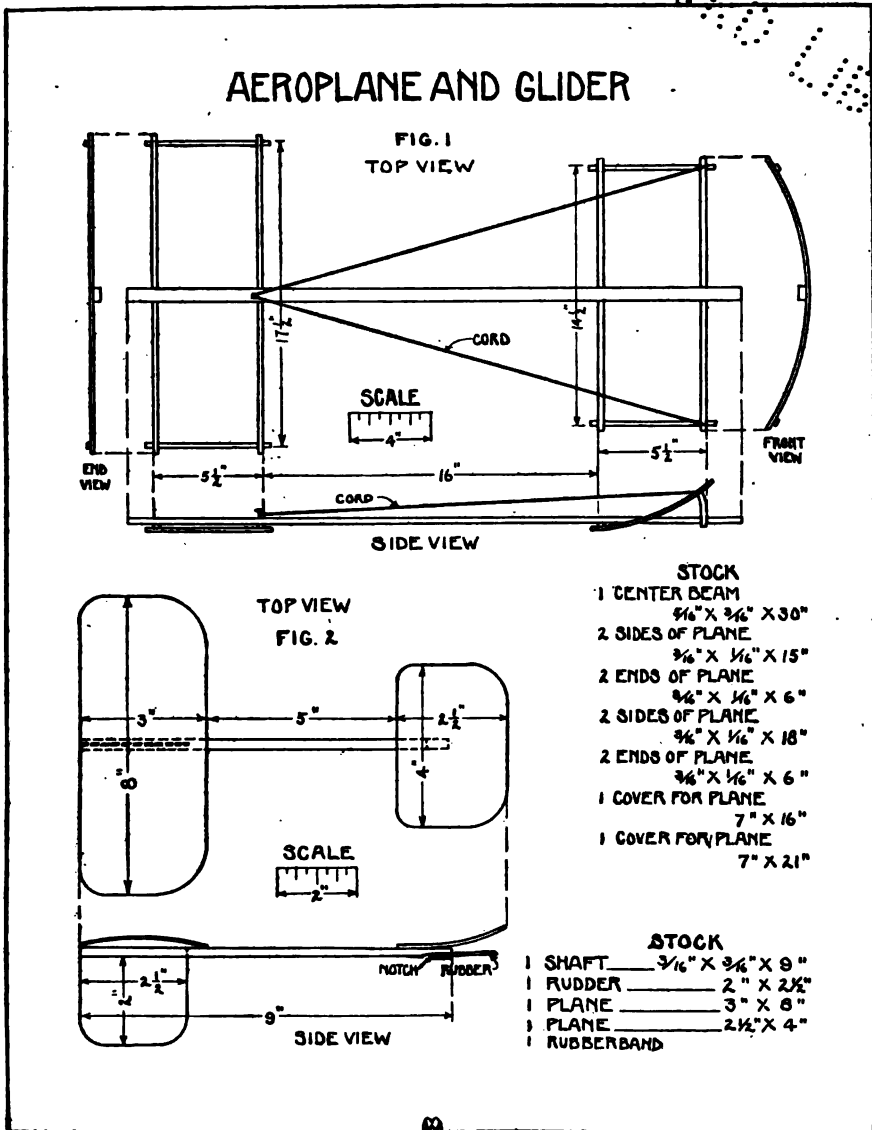

the side view of Fig. 2. To put the glider in motion hold the shaft in the fingers and throw it forward; or insert one end of a rubber band in the notch on the under side of the shaft and stretch as in a slingshot. When released the glider will shoot forward.



ANIMALS WITH MOVABLE PARTS. Figs. 1 and 3 show possibilities of cam movements made with a brad nailed to the axle. Fig. 2 shows a balancing or pendulum effect. In Fig. 1, the head pivots on the far end with the cam action in the middle part. In the photograph, the second figure on the top row shows one of the sides removed with the head raised by the nail and the head just ready to fall. In Fig. 3, the head pivots in the middle with the cam movement at the end. This type works easier than that in Fig. 1, but it is important that the lower end be the heavier so as to keep the head in an upright position. The bottom of the head must also be heavier in the balancing type as shown in Fig. 2. If it is desired that the tail move, it may be fitted up as suggested for the head.

All movable parts must turn freely. A wire may be used for the axle instead of a rod. For the cam, a projection can be soldered to the wire, or the wire can be bent "U"-shaped in the middle to give the cam effect and thus take the place of the projection. The "U" shape or crank projection pushes the movable part back and forth.

Wheels can be turned on the lathe, or sawed from a round piece of wood, or made with a washer cutter, or spools and button molds used.

Animal forms made to stand are suggested by the goat, donkey, and elephant in the photograph. The body part can be made solid with grooves cut in the ends to receive the head or tail. The head can fit between the two sides of the body, and the legs and arms fitted on each side. The movable parts should not swing freely, but

ANIMALS WITH HEAD MOVEMENTS

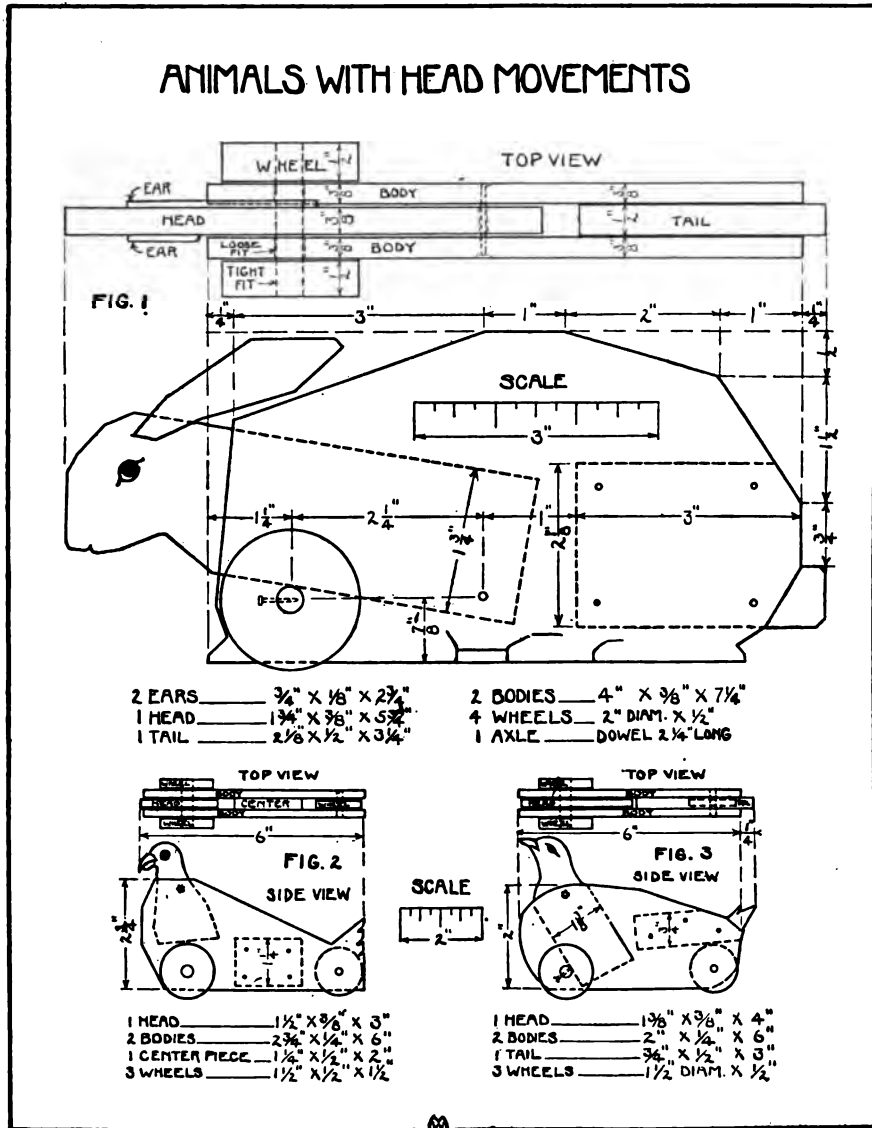

must fit tightly on the pivot so that they may hold in any position.

The toys made by the Dux Toy Company, of Concord, N. H., offer many suggestions for problems, such as the movable jaw, head, or leg, of dogs, ducks, frogs, alligators, grasshoppers, chickens, or birds.

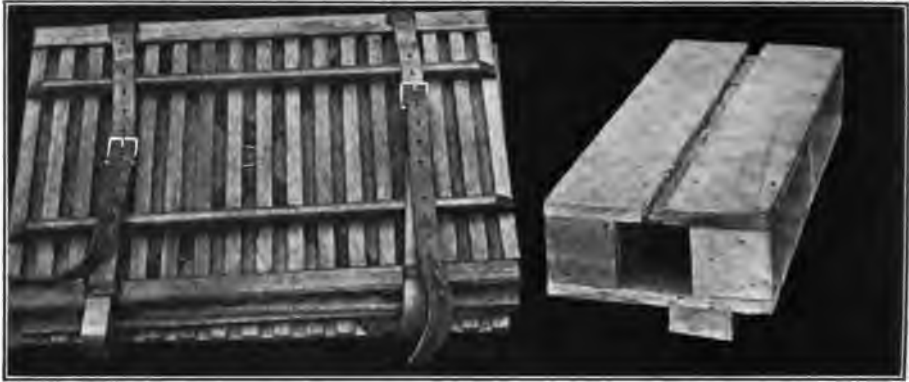

SPREADER — PRESS — CASE. The insect spreader as suggested in Fig. 1 is lined with cork or soft wood or cardboard. Note that the top pieces are inclined slightly toward the middle. To construct, first bevel the top pieces and then fasten them to the cross pieces. Next fasten on the pieces of cork or soft wood, and lastly nail on the bottom. Dr. Hodge's chapter on "Insect Study" should be read before attempting work in mounting.¹

The construction of the mounting case is shown in Fig. 3. On a piece of glass the desired size of the case fasten narrow strips of wood just the thickness of the largest specimen. Fasten the strips to the edge of the glass with shellac, and you have a box with glass bottom and wooden sides the depth of the largest specimen. The specimen should be fastened to the glass with minute drops of glue where it touches the glass. Glue sometimes dries so hard that it scales off on the glass. To prevent this, twenty drops of glycerine should be added to each ounce of glue. After the specimens are set, cover the box with a piece of glass just the size of the bottom piece and bind the two glass covers to the box with a strip of gummed passepartout tape around the edge wide enough to hide the wooden frame. This method of mounting suggested by Dr. Hodge enables one to see both sides of the insects, which is a great advantage over the old plan.

In the construction of the press as suggested in Fig. 2, two nails should be put in each lap. The nails should be long enough to be

¹ C. F. Hodge, *Nature-study in Life*, p. 56.

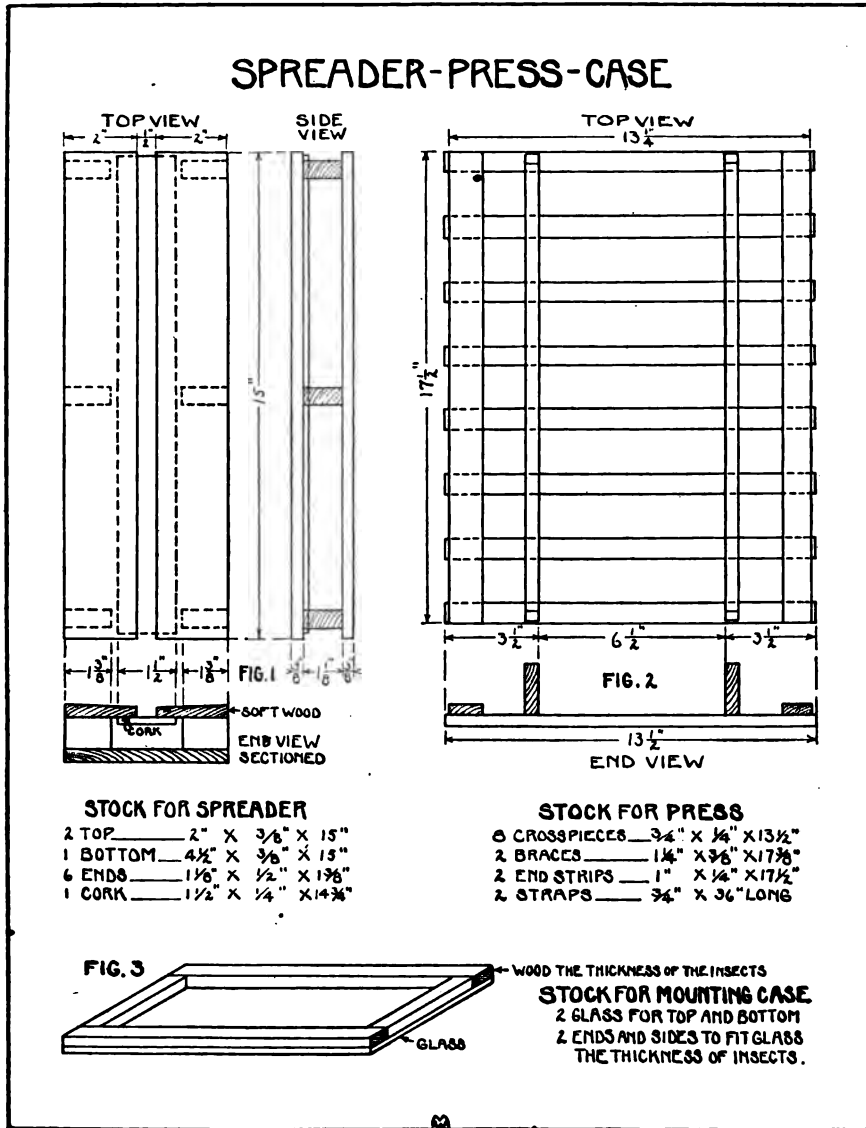

bent over and clinched. Two sides must be made. Two pieces of bookbinder's board or heavy cardboard should be used between the two sides. To hold the straps in place put on strips of leather, or strips of metal as shown in the photograph.



THE ROLLER COASTER. In hilly localities there is always a great demand for the roller coaster. For most boys the making of the wheels and axles is a difficult undertaking and is apt to result in discouragement. For satisfactory results, they should be of hard wood, turned on the lathe or sawed on the band saw, and accurately bored. If it is desirable to secure them ready made it will be found that some woodworking mills are always willing to use up their scrap lumber in making them, provided a sufficiently large order is given. The most convenient and inexpensive way is to arrange with the local toy or candy shop to buy them wholesale and retail them to the boys as needed. Sets of two sizes are manufactured by E. B. Estes & Sons, 74 Warren Street, New York City. The wheels of the smaller size are $3\frac{1}{2}$ " in diameter by $\frac{7}{8}$ " thick, and the axles are 15" long by $\frac{7}{8}$ " square; the wheels of the larger size are $5\frac{1}{2}$ " in diameter by $\frac{7}{8}$ " thick, and the axles are 19" long by $\frac{7}{8}$ " square. These are sold to the trade by E. B. Estes & Sons, so as to retail the smaller size with a reasonable profit at ten cents per set (4 wheels and 2 axles). They are of a hard wood and reasonably well made.

The simplest form of roller coaster is herewith shown. It is made by fastening the axles directly to the body board. A heavy cord fastened to the front axle can be used for steering, and a cross piece can be used for a foot rest as shown in Fig. 1. The heel of the shoe touching the ground serves the purpose of a brake. In the wheels and axles sold by E. B. Estes & Sons, three kinds of holes are already

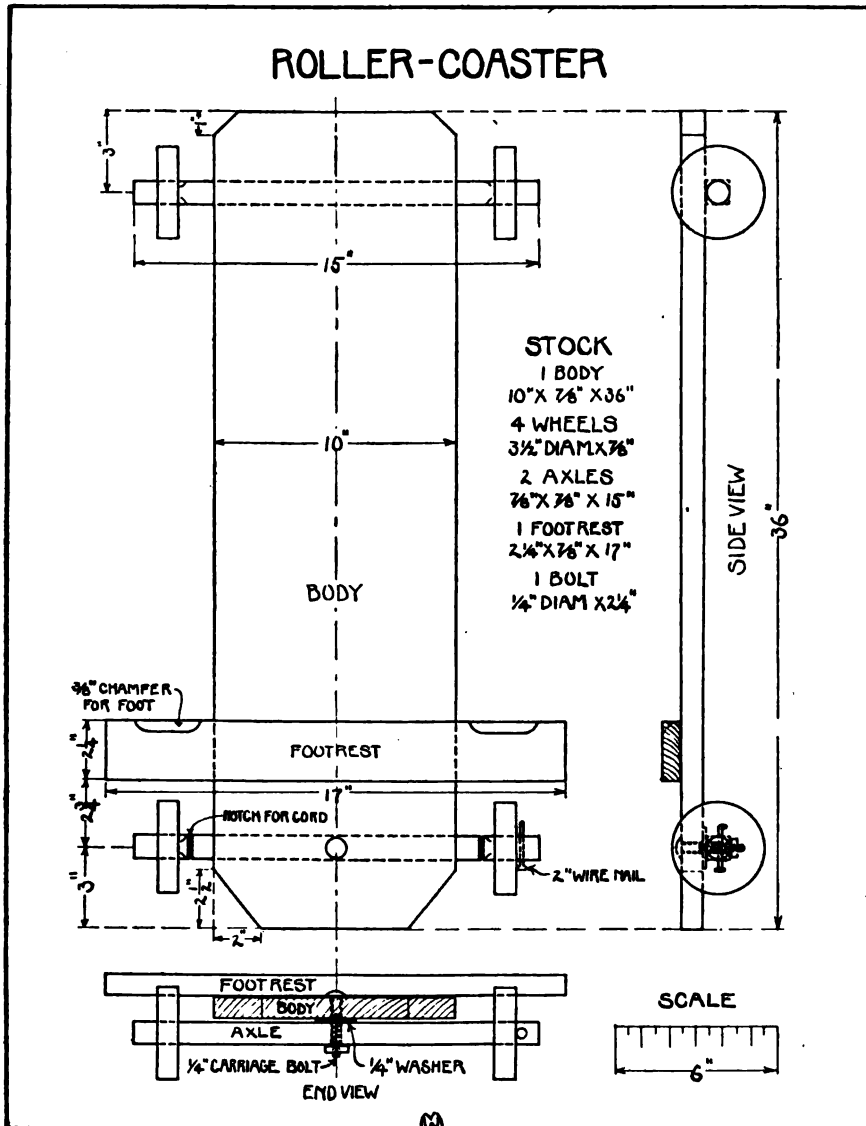

provided in the axles: a bolt hole in the center of the front axle, holes for screws to fasten the axle to the body board, and holes for nails at the ends of the axles to prevent the wheels from coming off. For further construction of Roller Coasters see pages 126 and 127.



TABLES. See page xxi for general suggestions on furniture construction. The simplest type of a table is that shown in Fig. 4 and in the photograph. This type of construction has already been described in rustic furniture on pages 18 and 19. The usual type of table construction is that in which the rails are mortised into the legs, but for our purpose this type requires too much technique and takes too much time for construction.

Fig. 1 shows the square legs with the rails fastened around the outside of them. This construction with the legs tapered is shown in the photograph. To construct, fasten the end rails to the legs first, next fasten on the side rails, and lastly the top. If no nail holes are desired in the top, blocks must be used to glue the top to the side rails. In Fig. 2 the legs are each made of two pieces joined at the edge, forming a right angle. To construct, first nail the wide part of the leg to the end rail, letting it project the thickness of the rail plus the thickness of the leg piece. Next fasten the side rails in place, and lastly fasten the side pieces of the leg in place, being careful to have a tight joint in the leg. Be sure to chamfer or round the bottom edges.

Tables with round, square, or octagonal tops can best be constructed as in Figs. 4 and 5. In the Fig. 4 type of table the shelf and the rail piece should be thick enough to act as braces. They should be shaped up together by pinning the pieces together with two nails or brads. The edges must be perfectly square, and the legs securely fastened to them.

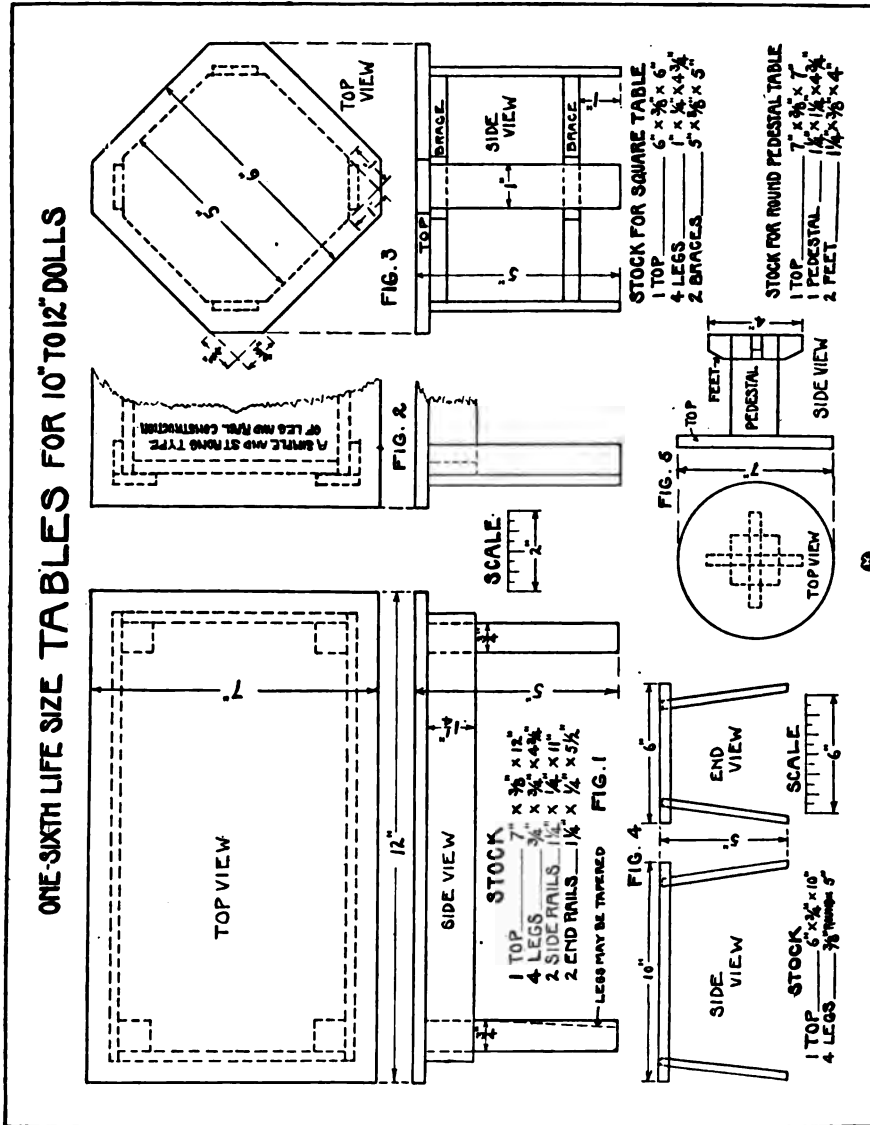

In Fig. 5 the pedestal and feet can be cut from a solid block, but a crosslap joint is therein suggested. The foot pieces are set up into one end of the pedestal, and the top of the table fastened to the opposite end.

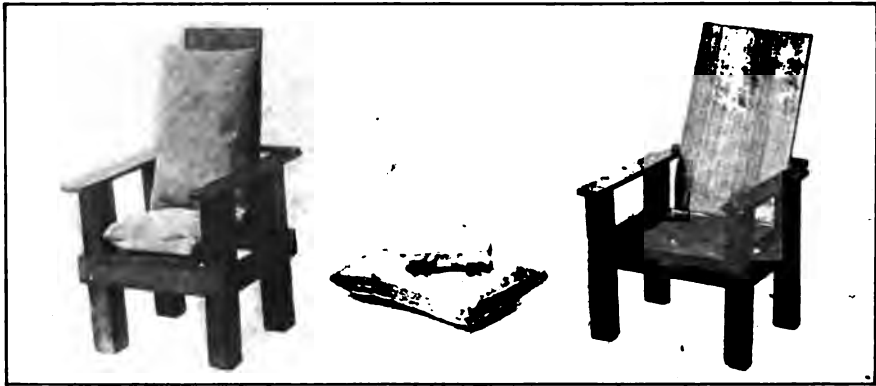

MORRIS CHAIRS. For furniture construction, see page **xxi**.

The morris chair leads in interest with both boys and girls. In this construction it must be remembered that it has not been planned full size for ordinary use, but for doll furniture to be readily made by young children. When well put together it stands hard usage.

To assemble the chair as shown in the drawing, first fasten the legs to the seat with one brad in each leg, and then fasten the rails to the legs, first the side rails and then the front and back rails. Before putting the back rail into place, secure the back of the chair to it by means of a strip of leather or cloth, so as to hold in place the stop for the back, and then fasten the arms on top of the posts and legs.

If better construction is desired, the rails can be gained into the legs as suggested in the lower left-hand corner of the bottom view. The morris chair to the right in the photograph is also of this construction, while in the one to the left the construction is of the simpler type.

If cushions are not used, the rails must be high enough so that the top of the seat is the proper height and even with the top of rails.

Cushions can be made with one seam as the ones on the chair shown in the photograph. The more desirable ones are made like those shown between the two chairs. This construction is suggested in the drawing. One piece each is cut for the top and the bottom, and one strip for sides and ends. These sewed together make a rectangular box shape. Leave one seam partly open, pack with cotton, and then sew this seam up. To hold the cotton in place and to

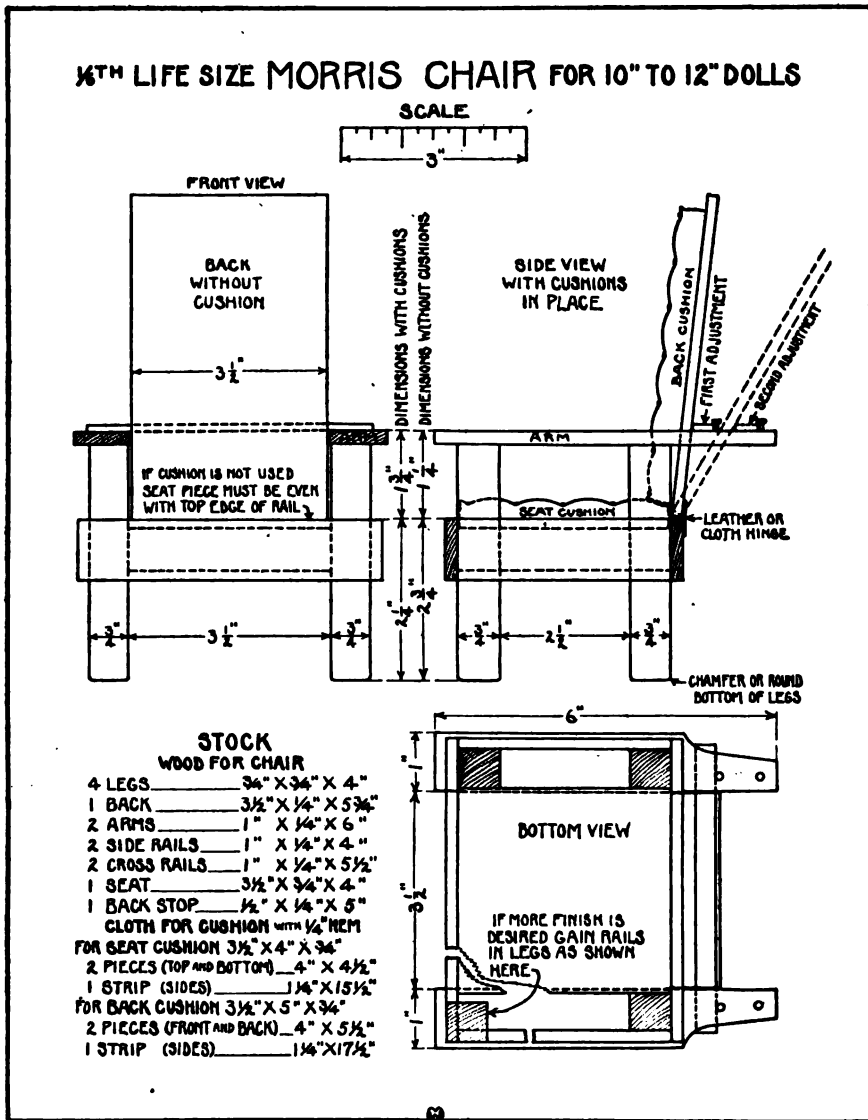

prevent the cotton from massing in one place, tack through from top to bottom in several places as shown in the side view of the drawing.

If the rails have been gained into the legs, the inside of the chair will be 1/2" wider; and the cushion should be 1/2" wider than planned.

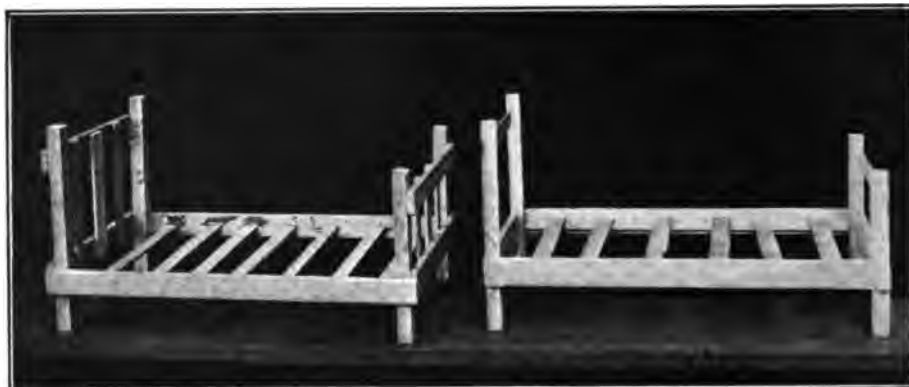

BEDS. For remarks on furniture construction, see general suggestions on page xxi. The construction of the bed (Fig. 1 of the drawing) is shown in the photograph. It must be remembered that this type of furniture construction is not designed full size for ordinary use in the home, but for the furnishing of the doll house to be made by the young children. The rails of the head and foot pieces are gained into the posts, and the uprights of the head and foot pieces are nailed to these rails on the inside, as seen on the right in the photograph. If less work is desired, the rails can be nailed directly to the posts without gaining them in, and the uprights can be omitted as is shown on the left in the photograph. If even less work than this is desired, the head and foot boards can be made solid of a single piece each. The main objection to this is that pieces this wide are liable to split warp.

To assemble the parts, fasten all of the pieces of the headboard together with glue and nails. Two nails should be used in each joint at the end of the uprights so as to brace the pieces properly. Next, fasten the slat supports to the inside of the side rails to the head and foot boards. To prevent the slats from getting lost, fasten them in place with a drop of glue and a brad at each end.

A crib can be made by making the bed a smaller size, but with the side rails higher to prevent the baby from rolling out.

If a cradle is desired, make a box with the end pieces wide and long enough to form the rockers. A medium size cigar box may be used, and the rockers fastened to the ends.

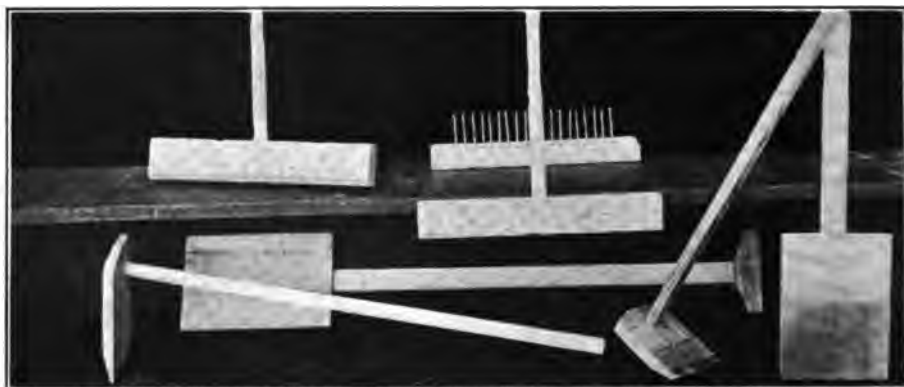

GARDEN TOOLS. These tools can be used in the sand pile or in the garden after the hard soil has first been broken up.

After the working edges of the hoe and the spade have been tapered to $\frac{1}{8}$ " or less in thickness, a piece of tin or thin sheet iron should be fastened around it with common wire nails long enough so that they can be bent over and clinched. The handles make excellent problems in round modeling. See pages 60 and 61. For the larger children the handle should be 1" in diameter or better still, $\frac{3}{4}$ " x $1\frac{1}{4}$ ".

Broom sticks make excellent handles for the hoe and the rake. When boring the holes for the handles, note that the handle of the hoe inclines slightly toward the front edge, and that the handle of the rake slants slightly away from this edge. The size of the hole in the rake block should not be larger than $\frac{3}{4}$ " in diameter. Fasten the handles in with glue, and secure by hammering a nail in from the top.

A simple, but less strong, rake can be made by fastening the handle to the top surface of the block piece. The teeth for the rake should be made of 10d, common wire nails. To prevent the block piece from splitting, $\frac{1}{8}$ " holes must be bored which are slightly smaller than the diameter of the nail. The nails must fit tightly. Tack a piece of sheet iron over the heads of the nails.

In making the spade, the top crosspiece and the blade must be securely fastened to the handle. Glue and fasten them with small carriage or stove bolts, or with nails long enough for the points to be bent over and clinched. The top end of the handle can be cross-lapped

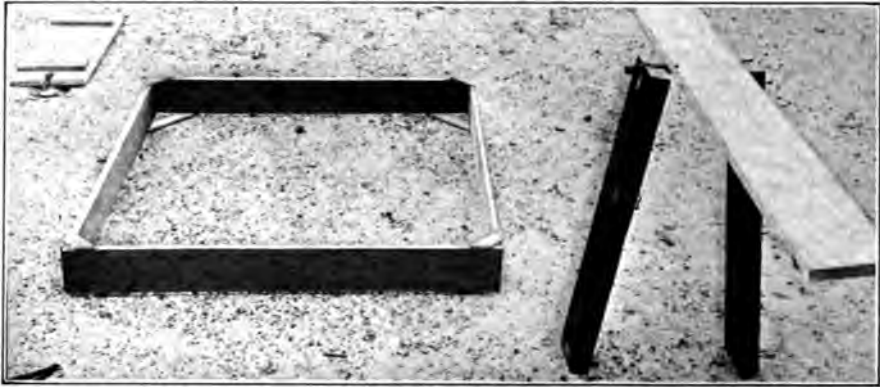

SEESAW AND SAND BOX. The teeter or seesaw, as suggested by Fig. 1, can be made any length and height desired. The teeter board should be straight-grained. The ends of it can be cut round, and the edges should be well rounded off. The lock block should be cut to receive the pivot and then fastened with screws to the center of the board. To prevent the board from wearing in the center, a strip of sheet metal can be fastened to the board where it comes in contact with the pivot. The pivot can be of iron or steel $\frac{3}{4}$ " in diameter; and, if for use by the larger children, it should be 1".

The uprights should be driven into the ground far enough to secure a firm foundation. If it is desired to move the teeter from place to place, a base can be used instead. This would require fastening the uprights to a rectangular frame and securing it firmly by means of braces in both directions. The arrangement shown in Fig. 1 allows for the removal of the board so that it can be put indoors out of the weather. Strips fastened across the ends of the uprights will lock the board in place and thus prevent it from being removed.

Fig. 2 is a suggested construction of a sand box 8 feet square. Strips across the corners, at the top and the bottom, are suggested for the braces. They are shown fastened to the edges of the sides, but a much stronger construction is to let them down into the edge of the sides. Large angle irons can take the place of the wooden braces. Strips of sheet metal fastened along the corners on the outside will also help to hold the corners together.

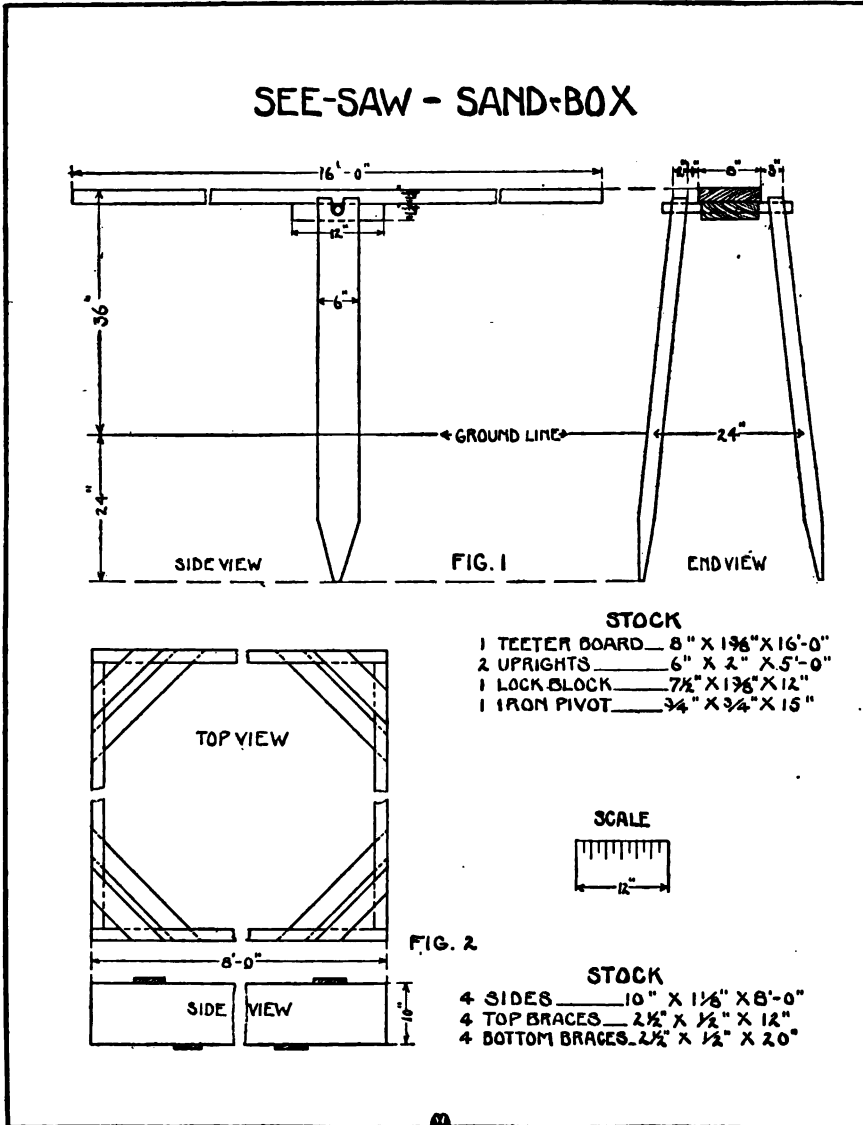

If the box is to be covered, it should be made narrower. If the box is 4 feet wide, the lid can be made of four boards 12" wide. Fasten them together with strap hinges. If the wooden lid is not desirable on account of weight, make a rectangular frame with a canvas cover.



JOINTED DOLLS. These dolls can easily be made by the younger children if a plain construction is used such as suggested in Fig. 1. Considerable care is necessary in locating the position of the nails and in putting them in, else they are liable to split the wood and necessitate making the pieces over again.

The slip joint construction as suggested in Fig. 2 requires much time and very careful work. The size suggested in the drawing is one-sixth life size, but for the younger children this size is somewhat too small. If a large size is desired, such as one-fourth life size, the best plan is to measure the size from life and divide by four. This will make a doll about 16" instead of 10" or 11" high.

In selecting the material it is very necessary that perfectly straight grain wood is selected, else the pieces will break off at the joints. In cutting the parts simplify the outline. The dowel in the head should be a tight fit, but readily adjustable. All the joints should be tight so as to be able to hold any pose desired. After locating the position of the nails or dowels, be careful to bore the holes at perfect right angles to the surface of the wood. If wire nails are used for the joints, the ends can be bent over and clinched. If a large-sized doll is made, $\frac{1}{8}$ " stove bolts can be used and the nut on the end can be sunk into the wood below the surface. The bolts can be run across the entire width at the shoulders and the hips.

Such dolls in the drawing room serve excellently for poses. Dolls to be used in connection with the house and the home furnishings

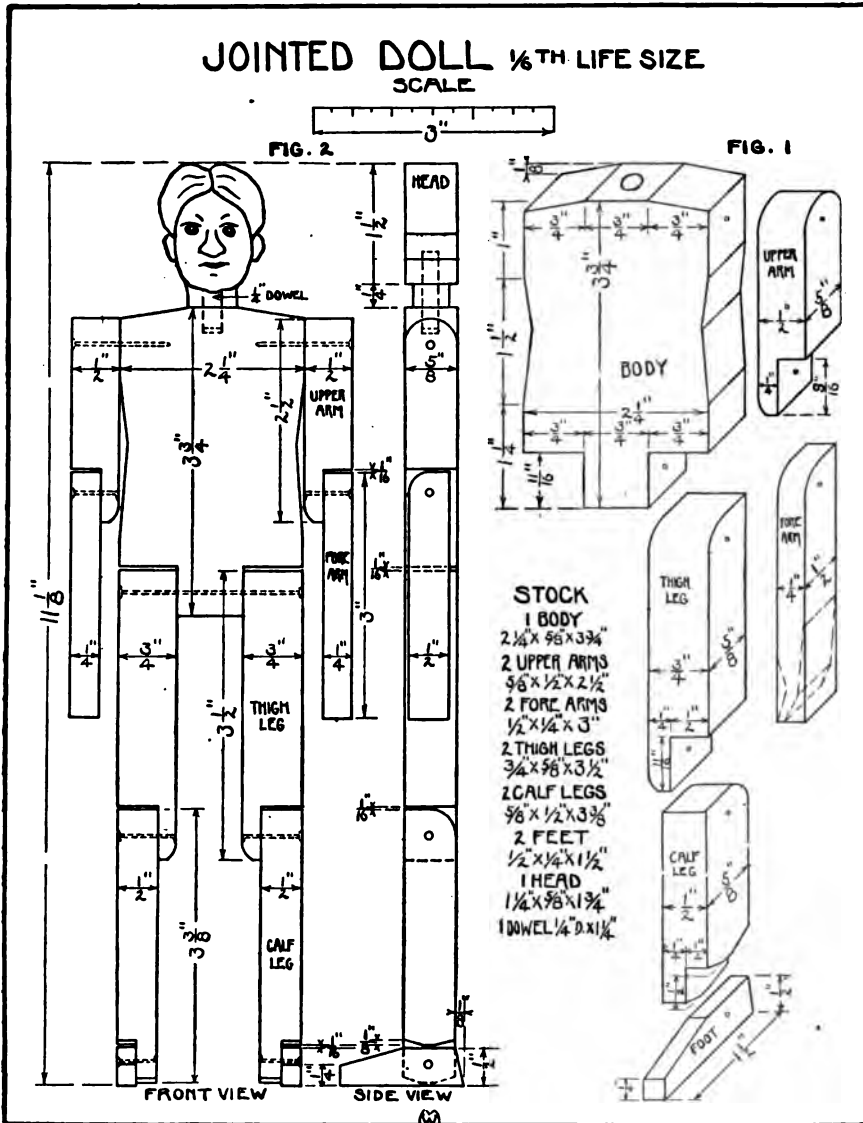

should be an appropriate size. Clothing to be put on and taken off can be made for them. The boy dressed, as shown in the photograph, is one of the "Do With" models manufactured by C. Pratt, 9 Jones Street, New York City.



RUNNING GRASSHOPPER. The grasshopper affords play for individuality in design. This can best be done by cutting paper outlines and using them as templates. Make the body wide to keep it from tipping over. If a narrow piece is used for the body, it is necessary to fasten lead or other metal to the underneath part of the body to avoid toppling over.

The legs can be fastened to the body at the shoulders, or they can be fastened to the wheels as shown in the photograph. The rear end of the leg should be fastened to the outside of the wheel in order to get the up-and-down eccentric movement. The wings may be fastened so as to be stationary; but if desired, a movement of the wings can be arranged. A slot in the wing through which a screw can be entered and fastened to the back part of the leg will admit of an up-and-down movement of the wing with every revolution of the rear wheels, as is shown in the drawing and in the middle figure of the photograph.

A ratchet wheel can be arranged underneath to give forth a clicking sound such as described on pages 96-98. If so, the axle for the front wheels must be of one piece and fastened tightly to the wheels. On the middle of this front axle must be tightly fastened the ratchet wheel, which can be made from an empty spool. The underneath part of the body must be cut or hollowed out to receive this wheel; and on the bottom of the body must be fastened a thin strip, so arranged that the free end of the strip will touch the ratchet teeth, which revolving, sets the strip vibrating and produces a clicking sound.

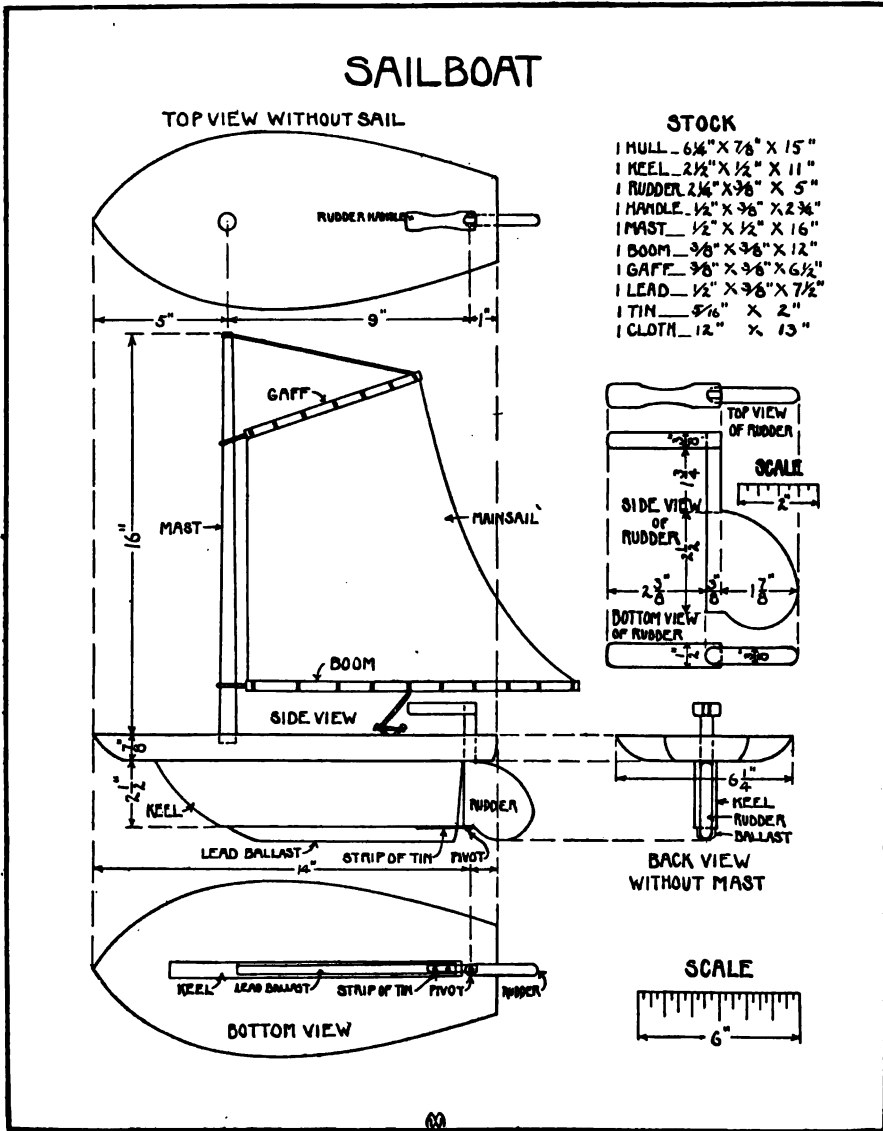

Fasten enough ballast of lead or other metal to the keel to keep the boat upright in a stiff wind. The farther the ballast is below the water line, the more effective it is in keeping the boat upright. When the keel is not very deep, the ballast can be suspended by means of wires.



WHEELBARROW AND WAGON. Wheelbarrows and wagons should be made large enough for practical use in the garden and the sand pile. The larger size can be made more satisfactorily than the small toy size, and if properly constructed will last for years.

The wheel for the barrow can be obtained from some discarded wagon, or it can be sawed out from a solid piece of hard wood, or bought at the store. See page 106. If the axle is made of a square piece as suggested by Fig. 1, a square hole must be made in the center of the wheel, and the ends of the axle rounded so as to revolve in holes bored in the ends of the shafts. If a round rod or dowel is used for the axle, the wheel must be securely fastened to it. Round the handles of the shafts. The bottom piece must be cut out so that the grain runs across and not lengthwise.

To put together the wheelbarrow as shown in Fig. 1, first fasten the wheel to the center of the axle and slip the axle into the holes in the ends of the shafts. The axle can be held in place by means of nails or cotter pins. The holes should be waxed before slipping the axle into place. Now fasten the bottom to the shafts, nailing it securely in place. Next, fasten the back and side pieces in place. Lastly, fasten the legs very securely to the sides of the barrow by clinching the nails or by the use of bolts. The use of angle irons or strips of metal at the corners makes a strong barrow. The wagon body (Fig. 2) is a box with one end arranged as a tailboard. Use angle irons or strips of metal to reënforce the corners. For fastening the wheels

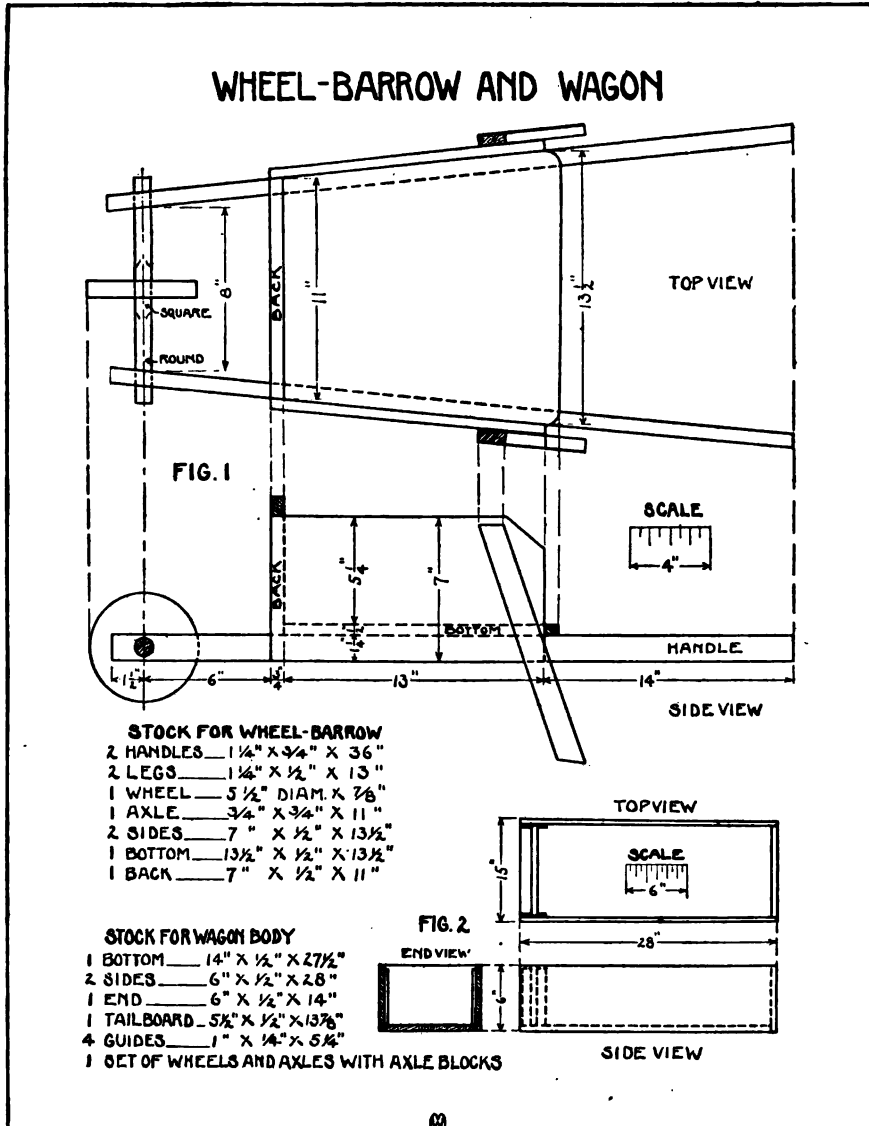

and axles see Roller Coasters on page 126. A board or part of a packing box can be used for the seat. Long nails can be used to fasten the shafts to the axle block, but a bolt running the full width of the wagon body is best. A harnessed goat or dog can be used to draw it.



ROLLER COASTERS. For suggestions concerning wheels and axles, see page 106. As shown in Fig. 1, the rear axles can be fastened to the body with nails or screws. A large nail can be used to pivot the front axle, but a bolt is much better. A washer between the front axle and the body enables the front axle to turn easily. The cotter pins are best to keep the wheels on, but nails with the ends turned are sufficient. Grease the axles before putting on the wheels.

The body board is cut away as shown in Fig. 2. The combination seat and tool box can be made by hinging the top of the box as seen in the photograph. An auto effect can be made by the arrangement of several boxes of suitable size. The steering can be done with a rope as seen in the photograph, or with the feet as arranged for in Figs. 1 and 2. The front of the body board must be narrow to give room for the feet on either side. If very accurate mortise and tenon work can be done, an upright with a steering wheel or crossbar, as shown in the photograph, can be used. This will take the place of the bolt. A hard wood broom handle makes a good upright. At one end cut a tenon about $\frac{5}{16}$ " by $\frac{3}{4}$ ", as suggested in Fig. 3. Cut a mortise in the front axle to receive this tenon, and fasten it securely into place.

Three forms of brakes are herewith shown: Fig. 2 and the photograph show a direct wheel brake and a ground brake; and the second figure in the photograph shows a brake-shoe arrangement.

If more finish is desired, carefully round or run $\frac{1}{8}$ " or $\frac{3}{16}$ " chamfers all around the top edge of the body-board. If large boxes are to be

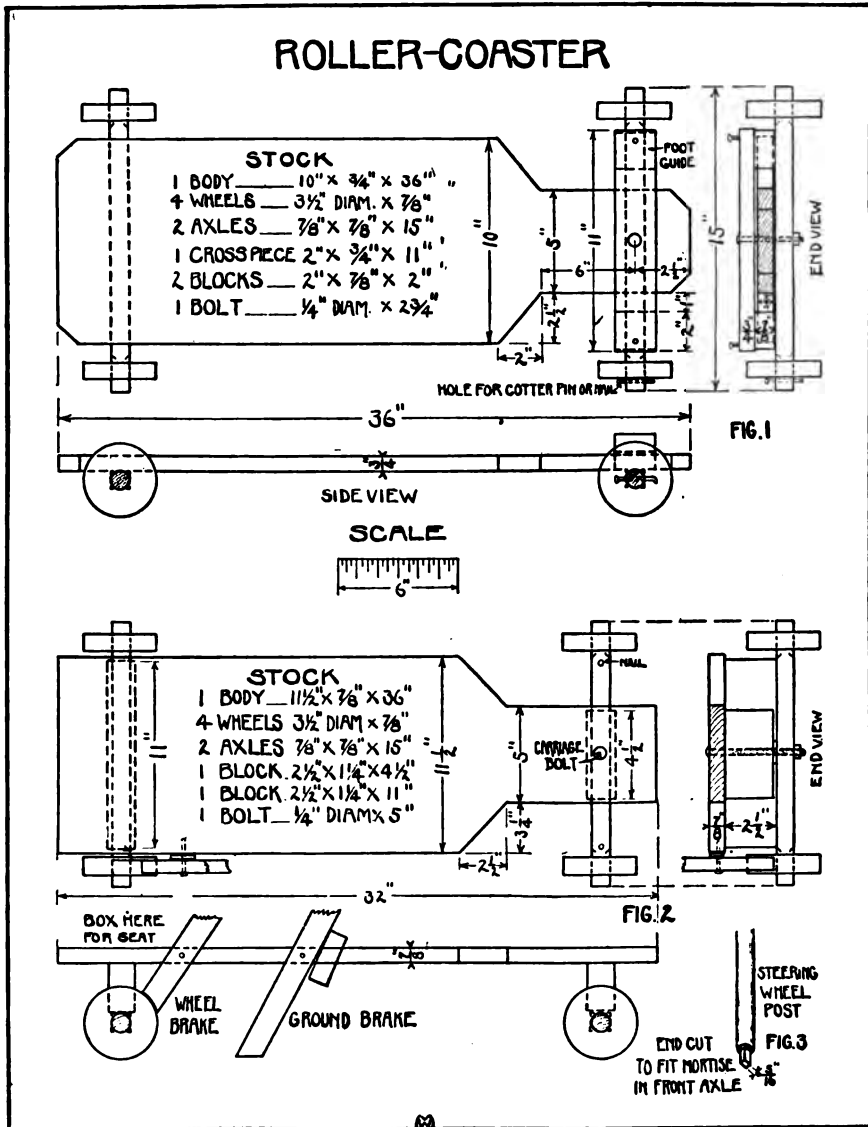

hauled, the body must be raised above the wheels by means of the blocks as seen in Fig. 2, so that the top surface of the body will clear the top of the wheels. If this is done, a large packing box may take the place of the body board.

VAULTING POLE — STANDARD — HURDLE. The vaulting pole should be made of a strong, straight grained, light weight wood such as white pine or spruce. For the younger boys, make it 6 feet long by $1\frac{1}{2}$ " diameter. Cut square; then model round. See page 60.



Drive a large nail or a piece of steel into the end. Let it project at least an inch and be ground or filed to a point. To prevent splitting, wrap with fine wire for several inches.

The vaulting or jumping standard involves the crosslap, and mortise and tenon joints. Cut the tenon on the end of the upright with a $\frac{1}{4}$ " shoulder. Bore the holes for the pegs, upon which the cords rest, at right angles to the length of the upright. Cut a $\frac{1}{4}$ " chamfer or round on the upper corners of the foot pieces. The sharp corners of the uprights should be taken off. Paint the figures on the upright before assembling the pieces. In fastening the parts together be careful that the upright is at perfect right angles to the foot. A 4" angle iron fastened at each side is necessary.

Dowels or large sized nails can be used to hold the cord. For the cord use a piece of fine rope about

12 feet long, at each end of which fasten a triangular shaped bag filled with sand or gravel; and a piece of white cloth at the center.

A 30" hurdle is suggested by Fig. 3. The legs are fastened to the top with an end-lap joint. If a $1\frac{3}{4}$ " thickness is used for the top pieces, the work can be laid out as suggested by the end view of the top piece in Fig. 3. This joint can be cut with the back saw.

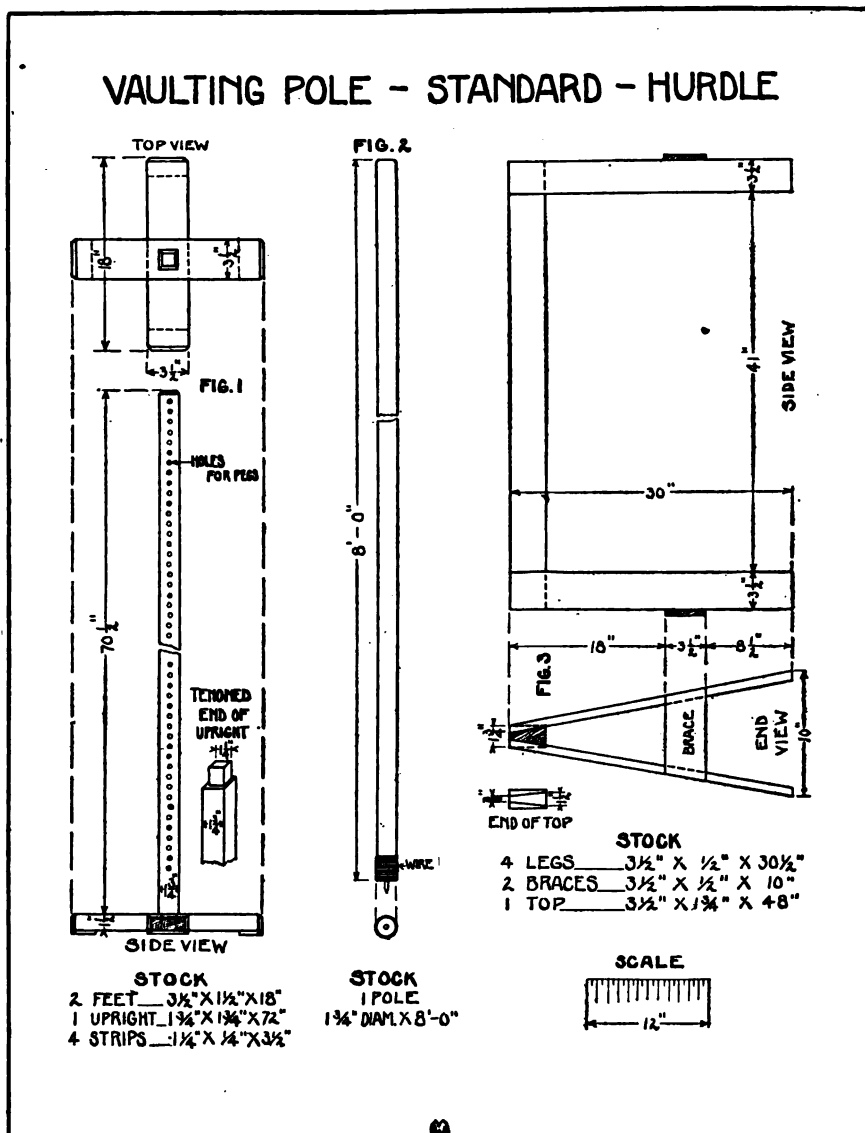

Fasten with glue and nails, screws, or bolts. If nails are used, clinch them. If more advanced technique is desired, the legs can be set into the top piece away from the ends and slanting outward so that the outer length at the bottom of the hurdle is about the same as at the top.

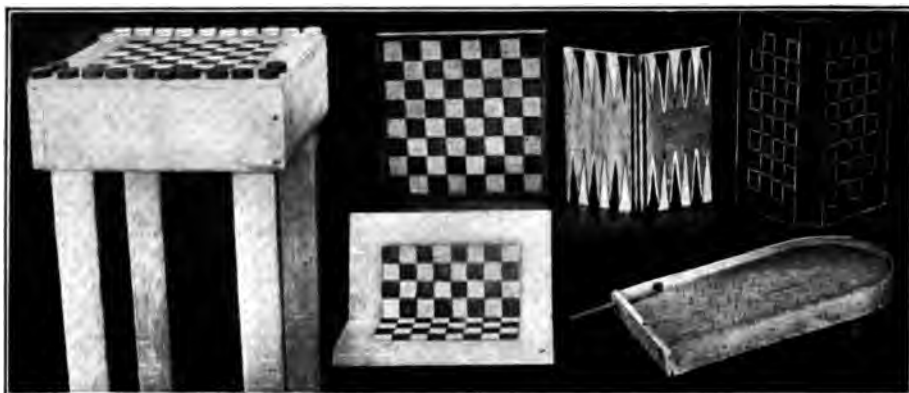

CHECKER, CHESS, AND BAGATEL BOARDS. For a simple checkerboard use a single piece of wood, or the bottom of a box. Lay out the squares not smaller than $1\frac{1}{2}$ " along each side. Trace the lines heavily and blacken each alternate square. The back of the board can be laid out for bagatelle. See Fig. 3.

For a folding board, small butt hinges can be used, or a piece of strong leather or cloth can be glued to the inside edges of the board.

For advanced technique, a glued up or "inlaid" board is a good problem. Use a dark and a light wood. Plane up four strips each, exactly $1\frac{1}{4}$ " wide. See that they are parallel, with perfectly square edges. Glue up with alternating colors as in Fig. 2. From the ends of this piece cut off eight strips exactly $1\frac{1}{4}$ " wide. See Fig. 2. These must be parallel, with perfectly square edges, else when arranged for gluing the squares will not match up properly. Arrange the strips with the proper arrangement of squares for the board as in Fig. 1. In this position glue them up, being careful that the outside edges of the large square thus formed are at perfect right angles to each other. An inch border strip of wood of another color about a middle value between the two kinds of wood already used, should be glued around the board. The corners of this border can have a butt joint, but a mitred joint is better. Plane the board smooth and level, and apply a natural finish of oil, white shellac, or varnish.

The twenty-four checkers should be about 1" diameter and made of the same kind of wood as the board. They can be turned on the

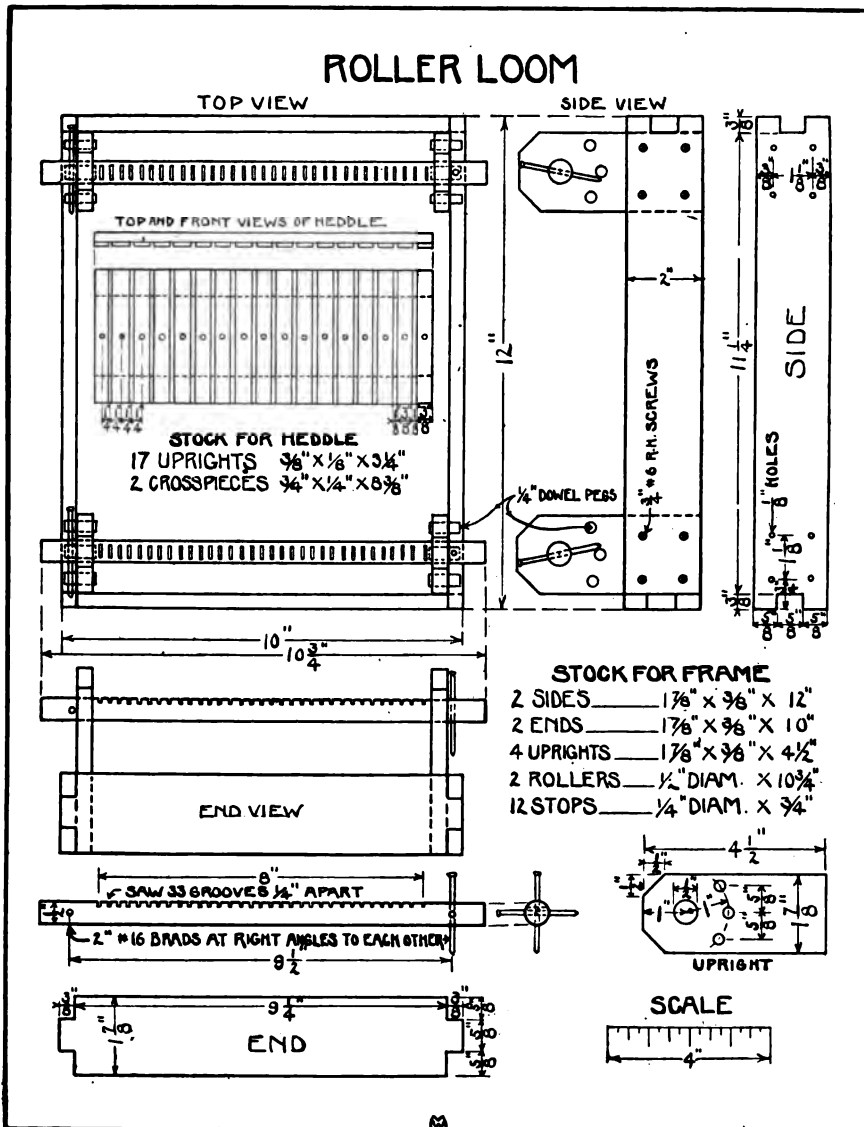

mentation. Many mechanical contrivances to facilitate the work of weaving have been worked out by classes. Many types of the heddles have been constructed, of which the one shown in the drawing is the best. Looms requiring more complex processes can be constructed.

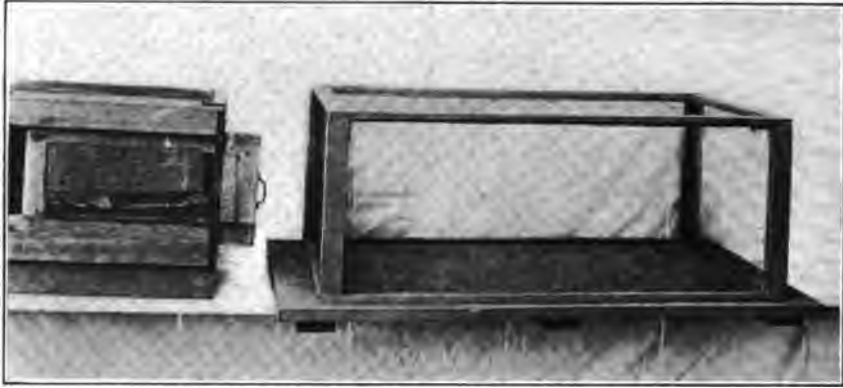

AQUARIA OR VIVARIA. Every schoolroom should have one or more fairly large aquaria so as to study the various forms of life at first hand. Filled with water, many forms of aquatic life can be studied; filled with earth it can be used as a root cage to study plant life at first hand; while with air alone it can be used as a breeding cage to study animal life.

The aquarium suggested by the drawing is a good size for practical purposes in the school. With a partition in the middle, two different kinds of aquatic life can be housed. For convenient handling by the children and for home uses, the single small aquarium is best. Many good objections are made to the usual wooden aquarium. The one suggested, although of wood, is not that of the usual wooden type. The best type of construction for the frame is the one made of metal as suggested by Dr. Hodge in *Nature Study and Life* on page 394. In some schools or homes, however, the construction of the metal frame is not possible. The wooden frame herewith designed has been planned to meet such conditions. When constructed properly, it has been found to serve its purpose very satisfactorily.

The method of construction is as follows: First fasten the battens on the bottom board, and cover the upper surface and edges with enamel, copal varnish, tin, oilcloth, or some substance that is water-proof. This protection for the wood is necessary, otherwise, if the receptacle leaks ever so slightly, the bottom board would swell up and cause the opening of many of the joints. Next, nail the two

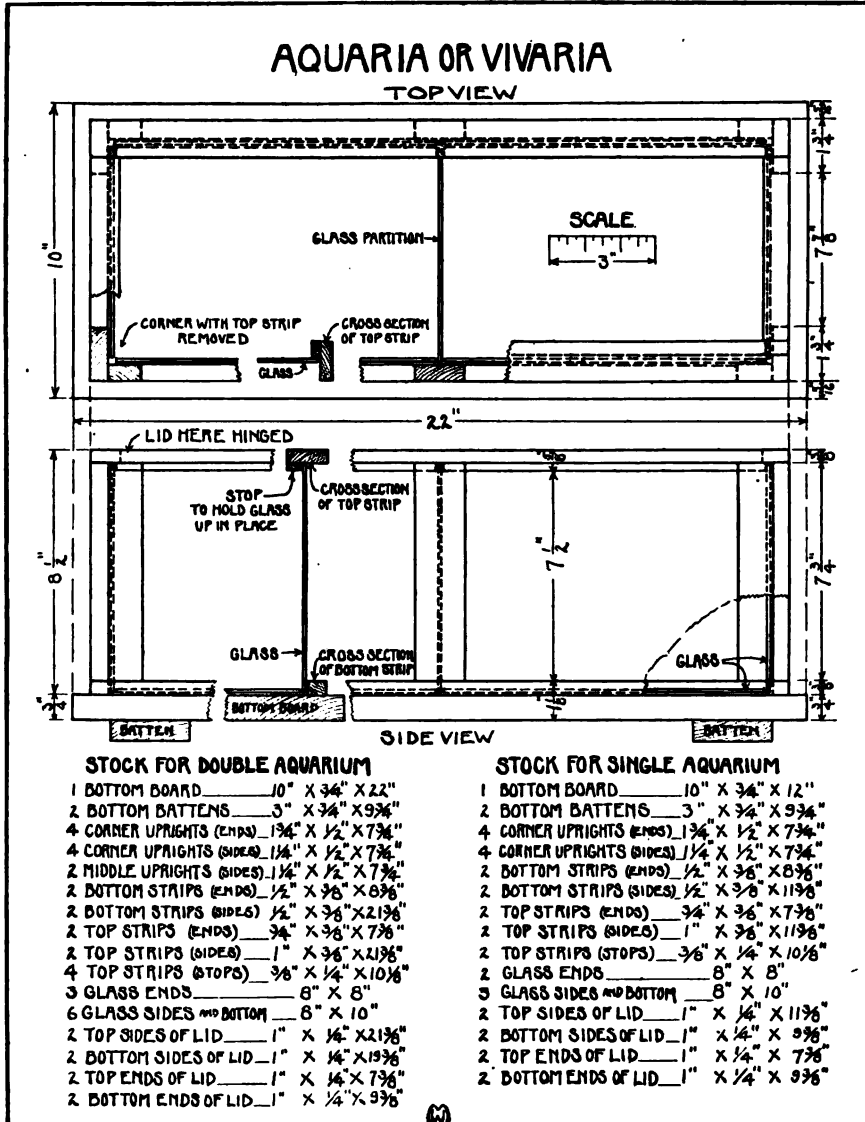

corner upright pieces together, and then nail the bottom strips in place on the ends of these uprights. Place in position on the bottom board. Now tack the top strips on temporarily with a nail at each corner. The glass used can be old photograph negatives, 8" x 10", which may

be easily cleaned off by using a hot solution of sal soda or other alkali. When the pieces of glass are ready for placing, the cement should be prepared. Dr. Hodge suggests several receipts. He says: "A good aquarium cement, for either fresh or salt water, is made by mixing dry ten parts each, by measure, of fine, dry, white sand, plaster-of-Paris, and litharge, and one part powdered resin. Mix, as required, to a stiff putty with boiled linseed oil. (This oil must be warranted free from any adulteration with fish oil, and it is commonly necessary to buy raw oil of a practical painter, who should know that it is pure, and boil it for a few minutes, to drive off the water in the raw oil.) The simplest and best aquarium cement, the formula of which has been given me recently by the United States Fish Commission, is made as follows: Stir together dry, by weight, eight parts putty (dry whiting), one part red lead, and one part litharge. Mix, as wanted for use, with pure raw linseed oil, to a consistency of stiff putty."¹

To lay the glass, first put a thin layer of cement around the bottom corners. Then set the glass down in it, leaving a $\frac{1}{8}$ " of cement between the surface of the glass and the wood. Next, lay the side, and then the end pieces in the same way. In all but the very small sizes the corners should be reinforced by filling the corners with cement and then laying over this a narrow piece of glass to protect the cement from the water. Extra care must be taken in pressing the glass in position, else it is liable to break. Hold the glass firmly against the frame while the cement is drying. To do this Dr. Hodge suggests the springing in of some limber green twigs. Trim off all the extra cement at the joints. After the glass is all cemented into place, the stop pieces should be fastened to the top strips. These pieces are located under the top strip along the sides, and are used to hold the glass up in place. These stops should be just long enough to touch the end pieces of glass, and the edge of the stops should press against the side pieces of glass. After locating the position of the stops, the top strips, which have been but temporarily fastened on, can be taken off, and the stops more easily fastened to them. The top strips should then be securely fastened in place.

¹ C. F. Hodge, *Nature Study and Life*, p. 399.

If a cover or lid is desired, it can be hinged along the edge. The eight pieces specified for the lid are used to make the frame of the lid. A piece of fine mesh wire netting, slightly smaller than the outside size of the aquarium, is necessary; 9" x 21" for the double one, and 9" x 11" for the single one. This is fastened between the two thicknesses of the wood, and the nails are securely clinched to hold it.

This aquarium should be set away for a week or more so as to allow the cement to harden. Dr. Hodge suggests the putting on of one or two coats of copal or spar varnish around the seams on the inside. No leak is likely to occur, but if it should occur, dry the aquarium thoroughly, and apply one or two coats of the copal varnish.

Dr. Hodge's directions for setting up an aquarium are as follows: "First, put in about two inches of sand, washed until a stream of water runs off clear; then, with the sand only moist, set the plants about the corners, making furrows in the sand in different directions and laying the roots in them; finally, arrange the pebbles, shells, and larger stones about the bottom where they will keep the plants in place. Next, pour in the water up to within an inch of the top, holding the hand or a piece of thin board to break the force of the stream, and avoid washing the plants loose. Finally, put in a fresh water clam or two, some snails, a few tadpoles (if the fishes will allow of it) to keep the water clean, and, after a day or two, such fishes — not more than two or three — as it is desired to study. Overcrowding is the common temptation to be resisted. Allow one gallon of water to each fish three inches long, and where enough water plants are present to oxygenate the aquarium, the fishes will show by their actions, quiet movements, and breathing, that they are comfortable.

"How often does the water require changing? The answer is: 'Not once a year, if the animals and plants and light are properly balanced and regulated.'

"Fishes and aquatic animals, in general, should not be fed oftener than once a day, and then only so much as will be eaten clean."

For further directions consult Dr. Hodge's chapter on "The Construction and Management of the Aquarium."¹

¹ C. F. Hodge, *Nature Study and Life*, pp. 393-404.

DOLL. The end-lap joint construction as suggested by Fig. 1 in the drawing of the doll is perhaps the best for all round purpose. The main advantage it has is that it can be very quickly constructed. It can be made larger if desired.



The important thing is to work out the several parts in proper proportion so as not to look grotesque, unless such is desired. If so, a great deal of amusement can be gotten from them. The best way to obtain the proper proportion is to measure the human body and reduce to the size desired. Such dolls well proportioned and constructed make excellent models for the drawing room.

Fig. 2 of the drawing on page 119 shows a construction that is more difficult than Fig. 1 and less difficult than Fig. 2 on the opposite page. This slip joint construction (Fig. 2) is a good opportunity for an exercise in tool processes. Good joints must be made if the dolls are to look well and work properly. For suggestions concerning the construction and assembling of the parts see page 118. If the doll is to be fairly large and to do much service, small carriage bolts to hold the parts together are desirable; or, if dies are

available, bolts can be made from heavy wire. A thread can be cut at one end, and the other end upset, and a slotted head cut with the hack saw. This, with the use of a screw driver, will admit of setting in the nut below the surface of the wood. Bolts at the shoulders and hips should extend the full width of the doll.

The facial expressions can be varied. They can be painted on by

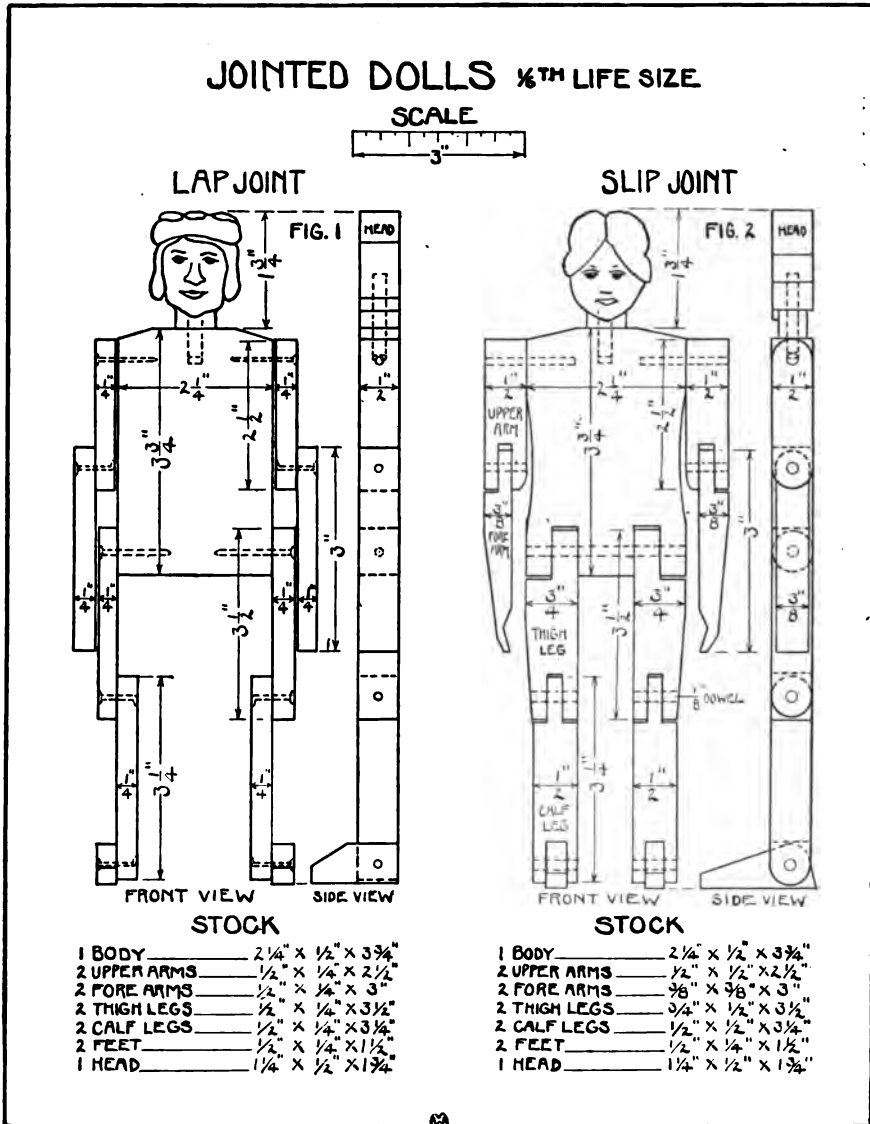

the boys talented in this line. Various costumes with which to dress the dolls can also be worked out by the classes. Mrs. Laura Starr's book on "Dolls" offers excellent suggestions for correlation with school subjects such as geography and history.



DAVENPORT AND CHAIR. For general suggestions on furniture construction see page xxi. The furniture shown above is a type of construction usually made. It should not be made, because it lacks the necessary bracing and will therefore go to pieces quickly after being used.

The davenport (Fig. 1) is the same type of construction as that of the morris chair on pages 110 and 111. The rails can be gained into the legs as suggested for the morris chair. If this is done, the seat will be $\frac{1}{2}$ " longer, since the legs will be moved out just the thickness of the two side rails. The drawing herewith shown is for use without the cushion.

If a cushion is used, the seat should be somewhat lower than the top edge of the rails, so as to make a pocket for the cushion. The rails will be $\frac{1}{2}$ " lower, as suggested in the drawing, so that the top of the cushion will be the proper seating height.

To assemble, first nail the legs to the ends of the seat with one brad in each leg. Next nail on the cross rails, and then the front and back rails. After it is carefully squared up, nail on the arms, and, lastly, the back rail even with the top of the arms.

If a divan is desired reduce to about one-half the length. To do so, simply deduct the same amount from all of the long pieces; for instance, if the seat is to be $5\frac{1}{2}$ " the top rail should be 7" and the other rails $7\frac{1}{2}$ ", the amount deducted being 5".

Cushions will add considerable interest to the problem. For directions concerning the making of the cushions see the suggestions given on pages 110 and 111.

DAVENPORT - CHAIR

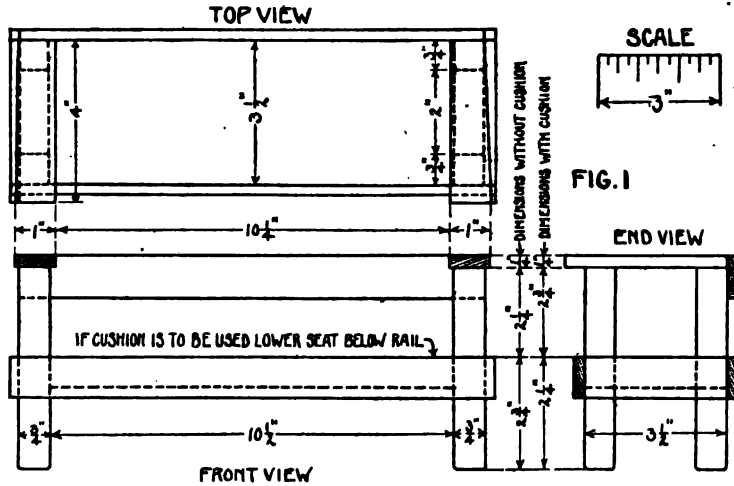

STOCK FOR DAVENPORT

- 4 LEGS $3/4" \times 3/4" \times 5"$
- 2 ARMS $1" \times 1/4" \times 4"$
- 2 SIDE RAILS $1" \times 1/4" \times 3 1/2"$
- 1 TOP RAIL $1" \times 1/4" \times 12"$
- 2 RAILS (FRONT AND BACK) $1" \times 1/4" \times 12 1/2"$
- 1 SEAT $3 1/2" \times 3/4" \times 10 1/2"$

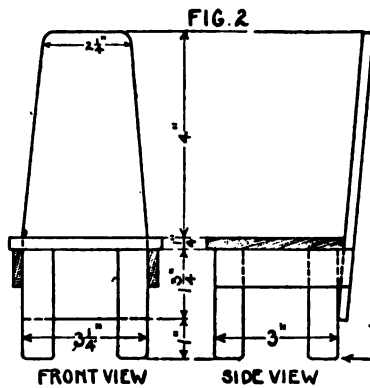

STOCK FOR CHAIR

- 1 BACK $3 1/4" \times 1/4" \times 6 1/4"$
- 4 LEGS $3/4" \times 3/4" \times 2 3/4"$
- 2 RAILS $1" \times 1/4" \times 3 1/2"$
- 1 SEAT $3 3/4" \times 1/4" \times 4"$

Fig. 2 has been designed for a hall chair. It is so constructed that the side rails are wide enough to act as braces in one direction and the back, which is lowered and fastened to the legs, acts as a brace in the other direction.

PLAN OF HOUSE ARRANGEMENT. Simple ordinary homes must be thought of in planning for the house. Various arrangements of the rooms can be considered; for instance the pantry can come between the dining room and kitchen, with the bathroom in the middle of the house; or the boxes can be turned so that the length of the front rooms runs across the width of the house, thus making the front of the house wider than the back. Practical conveniences will determine the arrangement of the rooms, such as having the pantry adjoining the kitchen and the kitchen next to the dining room. Not only must each room be a unit in itself, but all the rooms must be related so as to obtain unity in appearance and in the arrangement of the house. The one-floor plan, as shown in the drawing, has been found to be a very practical plan for a study of interior arrangement and decoration. Five packing boxes of similar size are used, one of which is sawed in two, one part being used for the pantry and one for the bathroom. Simplification of the problem necessitates the rooms to be all one size or at least all one height. The tops of the boxes are not used. This leaves the whole house open at the top so as to make the arrangement of the furnishings most convenient. If desired the boxes can be separated enough so as to leave a space between the rooms which can be used for closets. If very little floor space is available, put the living room, bedroom, and bathroom on the second floor. In this case one side of each room can be left open and access to the second floor can be had by means of a staircase of cardboard or thin wood. The boxes should be arranged so as to obtain good proportions in length, width, and height of the rooms. If large boxes only are available they may be divided into rooms by the use of cardboard or thin wood. A certain scale should be determined upon and then adhered to in every detail. The proportioning of everything to a scale affords excellent correlation with arithmetic.

If all of the furnishing is to be of paper and cardboard, one-eighth size or $1\frac{1}{2}$ " to each foot has been found to be most satisfactory. This will make use of boxes or rooms about 18" x 27" and an 8" or 9" doll. One-sixth size or 2" to the foot is best, however, if bristol board or cardboard is to be used, but if ordinary manila draw-

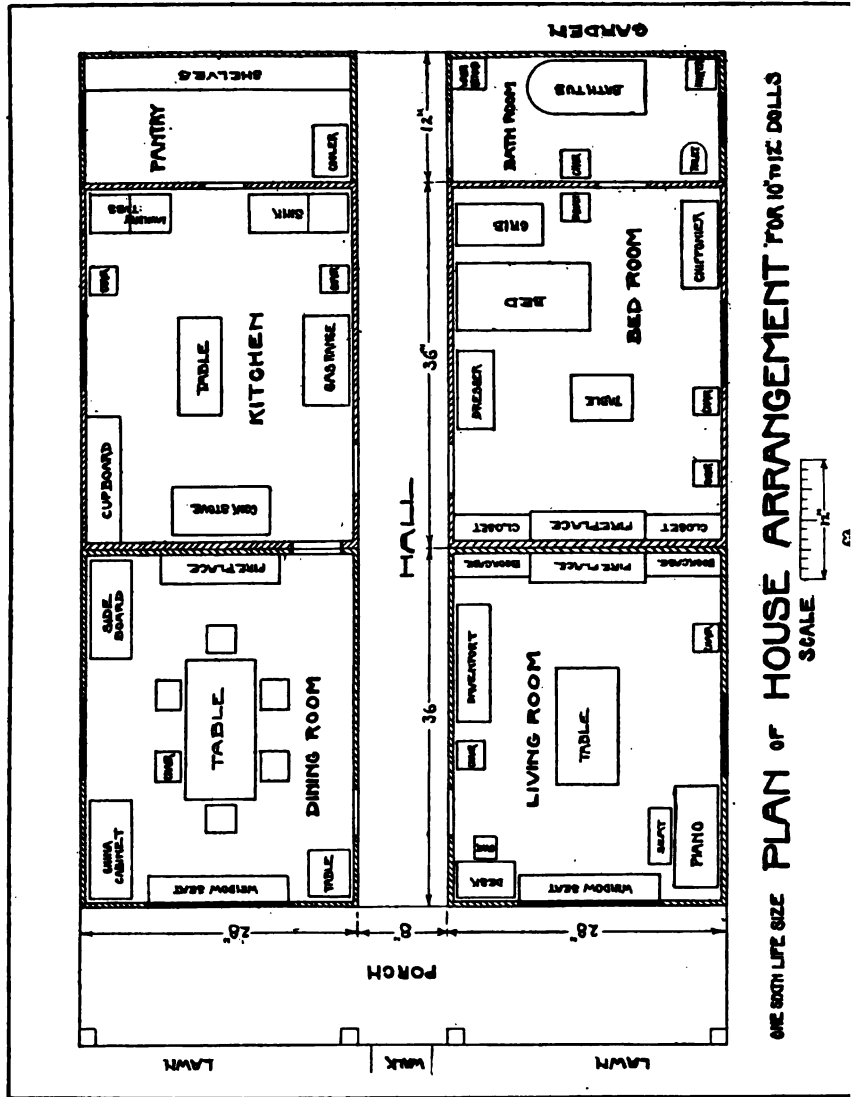

ing paper only is available, one-twelfth size or 1" to the foot is best. In this case a 6" doll will be used and the rooms will be about 14" x 18". The drawing has been planned with the thought of having the furnishings made of wood and a scale of one-sixth has been

selected as the smallest size practical. If wood is used for the furniture, a smaller size than that specified on the drawings should not be used, otherwise satisfactory results are not possible. From an economical standpoint, it has been found that packing boxes for the rooms one-eighth size can be more readily obtained from the merchants, and cigar boxes and cereal boxes can be utilized to better advantage in this size; but as previously said, if wood is to be the material used, the making of furniture this one-eighth size is not practicable from an educational standpoint. If plenty of space is available and economy in materials is unnecessary, then a one-fourth size is most suitable. If packing boxes are not desired, and plenty of lumber and a workshop are available, the house can be built in the shop. With advanced pupils actual house construction to scale can be planned and worked out, but with the younger children this is not desirable. One-half inch or one-quarter inch boards should be used. Porches may be added and a removable roof may be put on.

Where paper and cardboard have been used, this work in the second and third grades has been most successful. In the higher grades the work with these materials is considered by the older children as mere doll play, but when wood has been used for the furniture, the higher grades, especially the fifth and sixth, have regarded such work as real, even though it is in miniature.

A school superintendent after observing this work said, "I do not know who was most interested, the children or the teacher. When one considers the lessons learned in common-sense application of everyday problems in furnishing, one cannot but be impressed with the educational value of such work." Much inexpensive material can be obtained outside of school and much work done at home, such as table covers and portieres stenciled, rugs woven, mattresses, pillows, and cushions upholstered, and clothing made for the dolls.

A few words of caution are necessary; avoid attempting more work than can be satisfactorily finished, avoid long and difficult processes, else discouragement will result. Attempt only those things that can be readily and easily made, and always make it possible that the children will have something to show for their effort.

INDEX

- Aéroplane, 100
Animals with moving parts, 78, 80, 102, 120
Animal traps, 26, 90
Aquaria, 134
- Bagatel board, 130
Banjo, 4, 38
Barrel traps, 26, 90
Bats for peggy or tip-cat, 60
Bean-bag games, 16
Beds, 4, 112
Bench, tool, xxiii
Benches, rustic, 4, 18
Birds, 78, 102
Bird houses, 4, 88
Blacksmith boys, 54
Boats, vi, vii, xi, 4, 28, 122
Bolts, xix
Bow gun, 74
Box, 44
Box traps, 26, 90
Breeding cages, 86, 134
Bridge boards, 68
Butterfly, 6
Butterfly top, 2
Buzzer, 10
- Cardboard furniture, 143
Carron board, 64
Case for mounting insects, 104
Cement, xxi
Chairs, 4, 18, 110, 140
Checkers, 130
Chess, 130
Chicks with worm, 54
Chinese drum, 99
Cigar box problems, 4
Clickers, 96
Climbing jacks, 50
Clogging jack, 52
- Clothespin blacksmiths, 54
Clothespin jack, 48
Color tops, 2
Coping saw, xxiv
Cradle, 4, 112
Crokinole board, 64
Croquet game board, 64
Cushion for chairs and bed, 110, 112
- Daggers, 56
Dancing jacks, 48, 52
Darts, 76
Davenport, 4, 18, 110, 140
Dining-room chairs, 4, 108, 140
Dinkey birds, 78
Disc tops, 2
Dolls, xx, 118, 138
Drill, primitive string, 10
- Elastic pistols, 22
Elastic power boats, 28
Elastic sling-shot, 22
Eccentric running wheels, 20, 24
- Falling ladder, 82
Falling seesaw, 82
Falling teeter, 82
Fencing rods, xxiv, 62
Fifea, 38
Figure-four traps, 26
Flying tops, 6
Furniture, xxi, 4, 18, 108, 110, 112, 140, 143
- Garden labels, 12
Garden signs, 12
Garden sticks, 12
Garden tools, xxv, 114
Garden trellis, 12
Glider, 100
Grasshoppers, 120
Guns, 22, 74, 99

- Happy jack windmills, 37
 Hockey pucks, 72
 Hockey shin guards, 72
 Hockey sticks, 72
 Hoes, 114
 House plan, 142
 Humming bird, 38
 Hurdle, 128
- Insect bottle, 30
 Insect mounting case, 104
 Insect nets, 30
- Jacks, 48, 50, 52, 54
 Jointed dolls, 118, 138
 Jumping jacks, 50
 Jumping standard, 128
- Kaleidoscopes, 14
 Knives, 56
- Label, garden, 12
 Lever movements, 54
 Looms, 84, 132
- Manual training materials, xvi
 Map puzzles, 44
 Marble games, 68
 Marble rakes, 68
 Minnow nets, 30
 Mounting case for nature-study work, 104
 Mother-hubbard windmill, 34
 Musical instruments, 4, 38
- Nails, xix
 Nature-study apparatus, xxv, 12, 30, 86, 104, 134
 Nets, 30
- Paddle-wheel boats, 28
 Peggies, 58
 Peggy bats, 60
 Pendulum movements, 78, 80
 Pistols, 22
 Plant labels, 12
 Plant sticks, 12
 Plant trellis, 12
 Plug top, 2
 Pole jack, 52
 Polliwog nets, 30
- Popgun, 99
 Post-card box, 44
 Post-card picture puzzles, 44
 Press for nature-study work, 104
 Primitive drill, 10
- Quoits, 94
- Rake, garden, 114
 Rake, marble, 68
 Rattler, 96
 Ring-toss games, 8, 94
 Roller coasters, 106, 126
 Roller-loom, 132
 Root cages, 86, 134
 Roque boards, 64
 Rowboats, 28
 Running grasshoppers, 120
 Running wheels, 20, 24
 Rustic furniture, 18
- Sailboats, 122
 Sand-box for playground, 116
 Sawyer, 80
 Scissors jack, 48
 Screws, xx
 Seesaw for playground, 116
 Seesaw, falling, 82
 Shinney stick, 72
 Shin guards, 72
 Shovel, 114
 Sign, garden, 12
 Sling shot, 22
 Snow shovel, 115
 Solitaire, 66
 Spreader for insects, 104
 Stick, hockey and shinney, 72
 Stick, garden, 12
 Stilts, 70
 String musical instruments, 38
 Swaying figures, 80
 Swings, 42
 Swiss dinkey bird, 78
 Swords, 56, 62
- Tables, 4, 18, 108
 Target, 74
 Teeter, playground, 116
 Teeter, falling, 82

- Tip-cats, 58
Tip-cat bats, 60
Tools, xxiii
Tops, 2
Traps, 26, 90
Trellis plant, 12
- Ukelele, 41
- Vaulting pole, 128
Vaulting standard, 128
Vivaria, 86, 134
- Wagon, 124, 126
Washstands, 4
Weaving, 84, 132
Wheels, xx, 106
Wheelbarrow, 124
Whirligig, 6
Whistles, 38
Whistling instruments, 38
Windmills, ix, 34
Wrestlers, 23, 54
- Zither, 38

THE following pages contain advertisements of Macmillan books by the same author, and of kindred interest.

Community Civics

By JESSIE FIELD

Formerly Superintendent of Schools, Page County, Iowa, author of
"The Corn Lady"; and

SCOTT NEARING

Professor of Social Science, Toledo University, author of
"Income," "Social Adjustment," etc.

Cloth, 12mo. Ill., x + 270 pages. \$1.60

Community Civics is designed to train boys and girls in citizenship. It aims to teach them to see beauty, truth, strength, and opportunity in country life; to understand the meaning and purpose of community institutions—the home, schools, libraries, clubs, associations, and the visible means of public service; to work for the ideals of country, maximum production, effective methods of business, high standards of living, and thoughtful consideration of life's problems; and to take an active interest in community, state, and national affairs.

Community Civics is a moving treatment of civic affairs in the community and in the larger community of state and nation. It is concerned with the civic conditions and social agencies of to-day and to-morrow. It is suited for the use of children in elementary schools everywhere except those in large cities.

THE MACMILLAN COMPANY

BOSTON
CHICAGO

NEW YORK
SAN FRANCISCO

DALLAS
ATLANTA

The New Geographies

BY THE LATE
RALPH S. TARR
AND
FRANK McMURRY

First Book \$.65 Second Book \$1.10

The Tarr and McMurry New Geographies represent ideas that make the teaching of geography produce results. Distinctive features are :

1. The emphasis of humanized geography. The physiographic and geological studies in geography are made subordinate to the industrial activities, the history, the education, and the development of the people.
2. The basis in home geography. In the beginning of the course and throughout the course, the study of geography is constantly related to the pupils' own experiences.
3. The stimulus to self-activity. Pupils are taught how to study, led to think about human problems, and encouraged to use thought rather than memory in their study.
4. The organization of material. The material of instruction is grouped under topics ; topics are grouped under main topics. The individuality of each topic is recognized. There are frequent comparisons with the United States as a basis, and reviews.
5. The use of the type method. Wherever it can be used to advantage in presenting geographical concepts, in developing the ideas of institutions, regions, or industries, the type method is used.
6. The appeal to the interest of children. Interest is gained and held by an adequate treatment of topics worked out in sufficient detail to make the meaning clear.

In every feature The Tarr and McMurry New Geographies are in harmony with the principles of modern pedagogy. They challenge comparison.

THE MACMILLAN COMPANY

BOSTON
CHICAGO

NEW YORK
SAN FRANCISCO

DALLAS
ATLANTA

English Spoken and Written

By HENRY P. EMERSON

Superintendent of Education, Buffalo, New York, and

IDA C. BENDER

Late Supervisor of Primary Grades, Buffalo, New York

Book One—Lessons in Language for Primary Grades	\$.35
Book Two—Lessons in Language, Literature, and Composition50
Book Three—Practical Lessons in English Grammar and Composition60

The English Spoken and Written Series of textbooks in language has gained recognition for merit in teaching elementary English effectively. The characteristic features of the series are:

1. Definiteness and preciseness of aim. The chief aims of the English course—the mastery of oral and written expression and the development of the power of language appreciation—are kept constantly before the teacher and pupil.
2. Constructive language work. Interesting, progressive, and constructive language lessons are organized into a complete, definite, and effective course of instruction. In this course, oral English plays an important part. It is the basis of instruction and an important factor in the development of every topic.
3. Effective correlation. The language work is correlated with the other subjects of elementary instruction and with the material of instruction that is to be gathered by the pupils out of school life. The reading done in school and at home is, likewise, made the basis of particular individual language lessons.
4. Well planned treatment of language and grammar. Language training is the main purpose of the series. Training in English grammar is given its proper place in the course. It is introduced and emphasized at the right time.
5. Reviews. There is ample provision for review work. Every new principle is developed with a sufficient number of exercises for practice and review. Cumulative reviews are also provided.

The success with which English Spoken and Written has been used indicates that it endures well the test of use.

THE MACMILLAN COMPANY

BOSTON
CHICAGO

NEW YORK
SAN FRANCISCO

DALLAS
ATLANTA

The Health Series of Physiology and Hygiene

By M. V. O'SHEA

Professor of Education, University of Wisconsin; Author of
"Dynamic Factors in Education," etc., and

J. H. KELLOGG

Superintendent of The Battle Creek Sanitarium; Author of
"Man, The Masterpiece," etc.

Health Habits	\$.45	The Body in Health	\$.65
Health and Cleanliness55	Making the Most of Life65

The O'Shea and Kellogg Health Series of Physiology and Hygiene is devoted to the education of children for health. It presents a complete course of instruction, covering every phase of the child's physical health and welfare. These books and the lessons in each book have been written in the fullness of knowledge of the subject and with a deep and sympathetic understanding of the nature and the needs of children.

The characteristic features are:

1. The lessons encourage children to form health habits. They supplement the instruction given in physical training, play, and exercise toward the formation of habits of posture; and they establish the child in the right habits of bodily maintenance, rest, recreation, and personal hygiene.
2. The lessons harmonize the health work of the school, the home, and the community. They teach children also how to be of service to themselves and others in emergencies.
3. In these lessons children are taught the elementary facts and principles of physiology and hygiene. They are taught to understand with sympathy the machinery of the human body, its needs and processes, its purposes and functions; and they are taught to build up the fortifications and defences of the body against disease.

The Health Series of Physiology and Hygiene is adapted in every feature for use in elementary schools. The four books make a complete and noteworthy course of instruction. Each book is, however, complete in itself and can be used independently.

THE MACMILLAN COMPANY

BOSTON
CHICAGO

NEW YORK
SAN FRANCISCO

DALLAS
ATLANTA

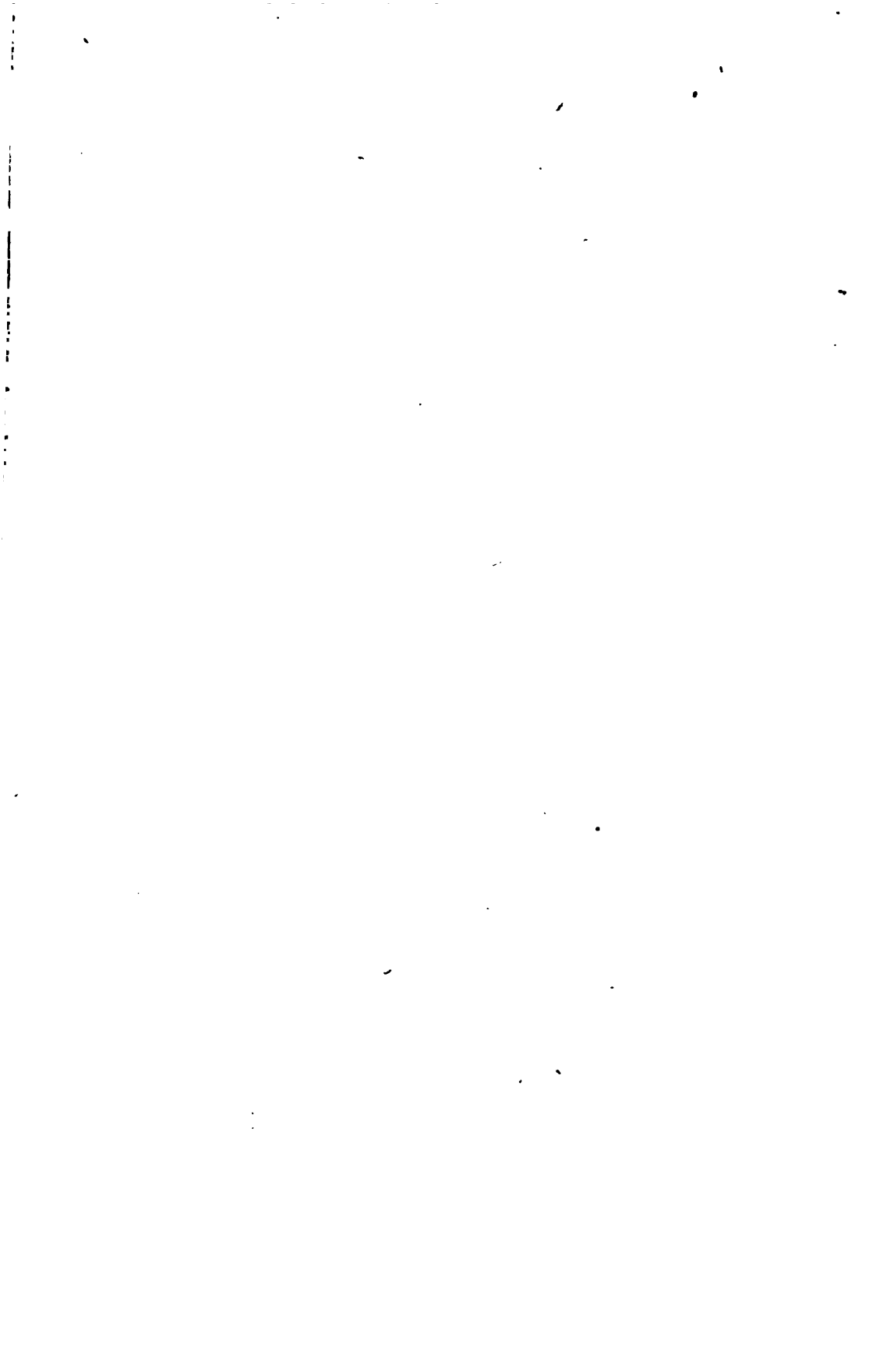

To avoid fine, this book should be returned on
or before the date last stamped below

ISM-7-42

JUL 2 1948

C

102

To avoid fine, this book should be returned on
or before the date last stamped below

ISM-7-42

JUL 2 1946
DEC 1952

